

V.300125



HIGHPROFILE AVENIR PRODUCT GUIDE: METRIC



TWO GUIDELINES

Orders that are released to TWO are processed in the most timely manner possible. As such, any changes made to an order once it is released to TWO cannot be guaranteed to be applied if the order is already in production. Initial costs, cancellations or any change costs will be the responsibility of the dealer to cover.

All drawings, notes and emails with questions must be answered before an order is entered in to the production line. Delays in the timely processing of these by customers will lead to longer lead times.

All factory/freight repairs are to have photographic/video proof. If neither are available at the time of placing the repair, it will be processed as a dealer responsibility. TWO will credit back the cost of the repair once proof of factory/freight responsibility is given.

For special request/non-standard/limited availability items please check first with Head Office for availability. Any surcharges for these items will be the responsibility of the dealer to cover, even if it is not listed on the price list.

PDF Estimates generated from the system may not reflect final pricing. If all items are not selected in the order form, or details are added to the notes section that may alter the price.

All dealers are responsible for having the most current price lists and product manuals. If unsure please contact your sales representative to confirm.

COLOUR OPTIONS

There are 6 standard powder coat matt finishes.

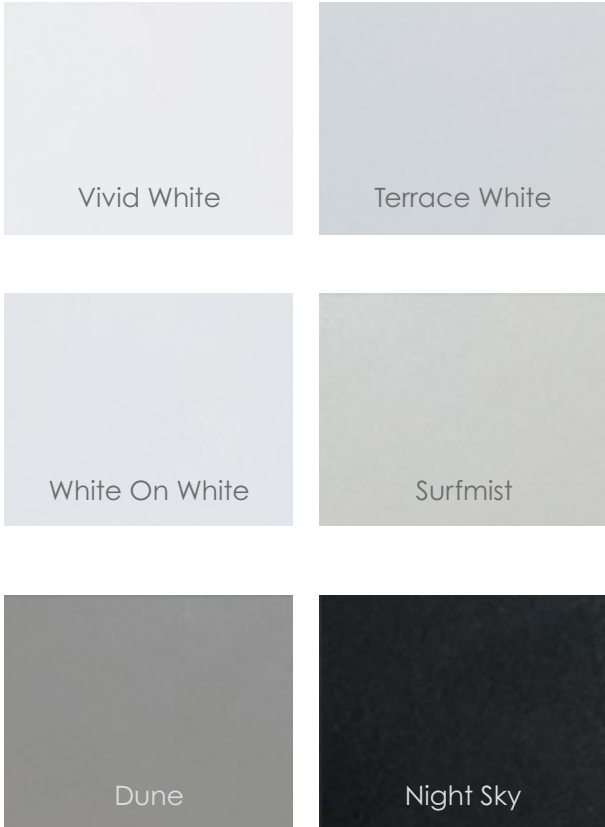

CUSTOM COLOUR FINISH

Choose from one of the many colours offered by Duralloy Dulux. Please be sure to select from the below pictured specifier for accurate colour matching "to deck".

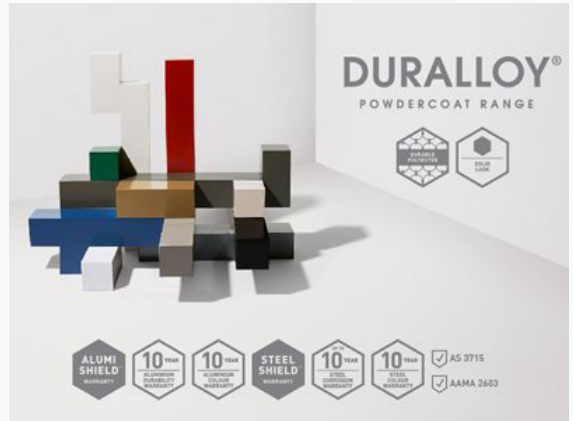

Please Note: Custom colour finishes are applied as a powder coat.

Powder coat finishes will be applied with a standard satin finish at 40% sheen. For custom sheen finishes e.g. matt or gloss, surcharges will apply. Metallic finishes not available.

BLADE

Available in 89mm blade
Please note blade end caps only come in black or white.

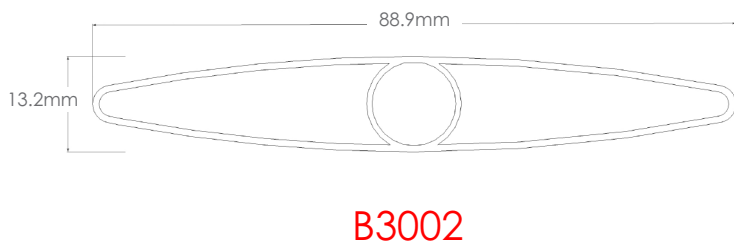

STILE

This product range offers a 52mm flat stile.

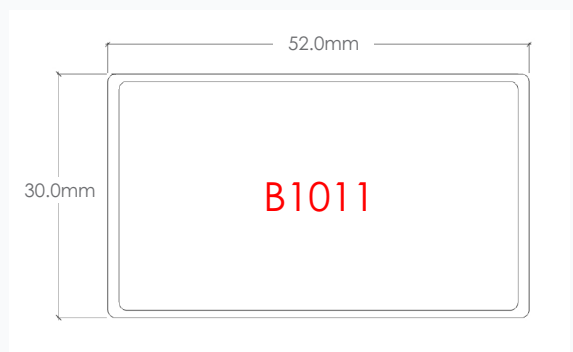

BOTTOM, MID & TOP RAILS

Top Rail & Bottom Rail

Mid-Rail

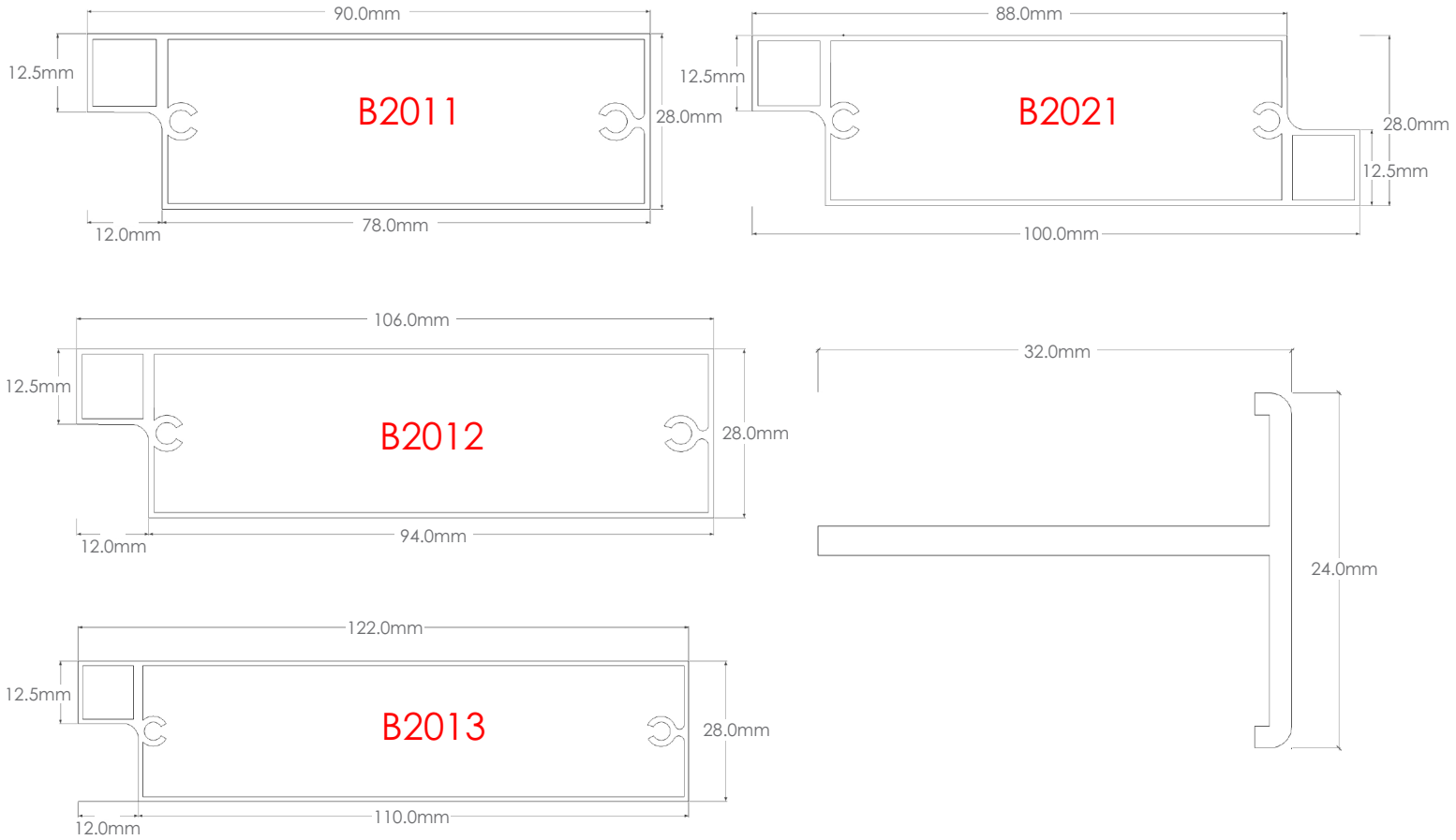

HOW TO MEASURE MID-RAIL HEIGHT

When measuring the mid-rail height it is important to measure to the center point of where you would like the mid-rail to be placed. As the mid-rail is the same size as an individual blade, it will be placed approximately +/- 40mm for the specified height.

Please note a critical mid-rail is not available.

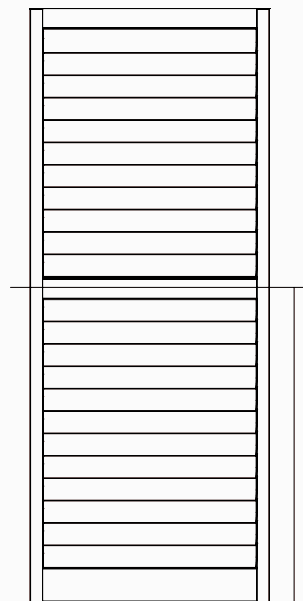

SPLIT ROTATION

Split Rotation is when the tilt rod is divided so that the blades can be operated in different sections. The split rotation is measured from the bottom of the opening to the requested split point. The blades are tensioned by tightening the screws where the tilt rod connects to the blades.

If no height is specified, the factory will automatically split the tilt rod when the height exceeds a certain limit. This ensures the structural integrity of the blades and proper blade closure. Check the warranty sheet for more details.

To request a split rotation when ordering, enter one of the following options in the Split Rotation Height field:

- 1/2
- 1/2 above midrail (if the item has a midrail)
- 1/2 below midrail (if the item has a midrail)
- 3 equal sections
- 1/2 above and below midrail (if the item has a midrail)
- Or enter the specific measurement you need.

The screenshot shows a configuration form with the following fields and values:

- Product Range: - all -
- Product: HP Painted
- Colour Range: New
- Color: Antique White USA (P137)
- Blade: 89mm
- Tilt Rod: Clearview
- Stiles: 51mm Flat
- Installation Method: Hinged in L Frame
- Installation Type: Flat L 47mm (4041)
- Mount: Face (Out)
- Panel Configuration: L-DR - 2
- Width: 1800
- Height: 1800
- Mid-Rail Height (mm): 400
- Uneven Panel Widths: No Yes
- Frame Options: 4 Sided
- Hinge Color: Default
- Split Rotation Height: 1/2 above midrail
- Special Instructions: #1
- Needs Drawing: No Yes
- Upload Drawing/Image: Choose file (No file chosen)

HOW TO MEASURE

REVEAL (IN) MOUNT

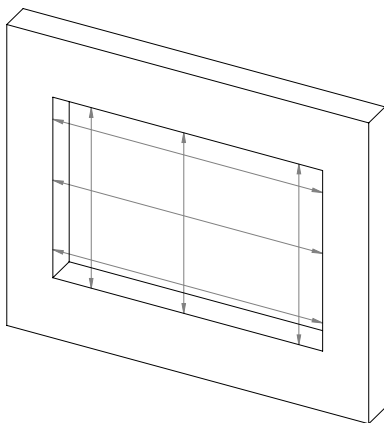

Width Points of Measure:
Top, Center and Bottom

Height Points of Measure:
Left, Center and Right

For Reveal openings, enter the smallest width and height of the measurements taken. All standard deductions will be taken for the units to fit inside the opening.

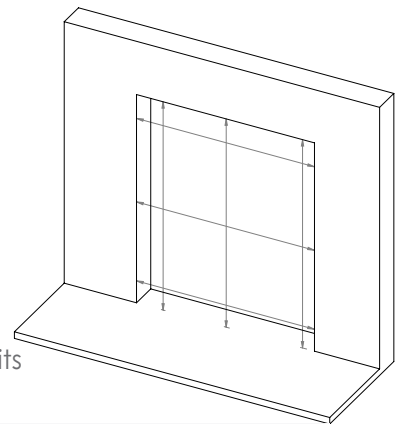

MEASURING TIP:
Always measure your opening from left to right.

FACE (OUT) MOUNT

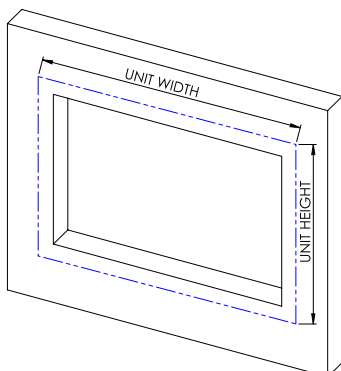

Width Points of Measure:
From the left to the right of the opening

Height Points of Measure:
From the top to the bottom of the opening

For Face Mount openings enter the width and height of the opening. No deductions will be taken. The measurements given will be from edge to edge including the frame.

SUB-WIDTHS: HOW TO MEASURE

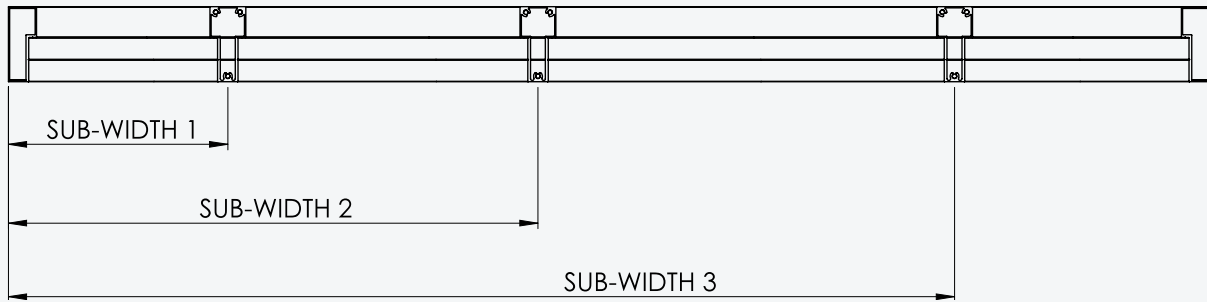

INSTALLATION METHOD: HINGED NO FRAME

BEFORE YOU ORDER:

WARRANTY LIMITS

Installation Method	Width			Height			Panel Breaks	
	Min	Max	Max Non Warranty	Min	Max	Max Non Warranty	Mid-Rail(s) Required	Approximate Split Rotation by Blade Size
								89
Hinged No Frame	200	1100	1200	400	3000	N/A	1500	1200
Double Hinged	200	500	600	400	2500	N/A	1500	1200

DEDUCTIONS

Panel and Reveal	Between Meeting Panels	Between Meeting Panels with D Mould	Hinge Deductions	Overall Panel Deduction for Non-Mortise Hinged
2.5	2.5	5	2.5	5

PANEL CONFIGURATIONS

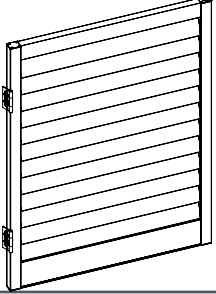
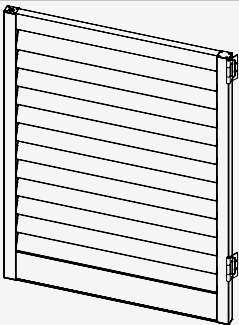
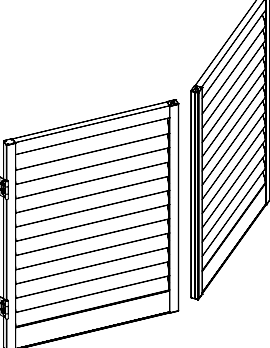
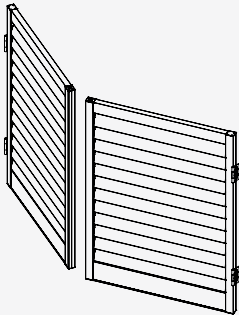
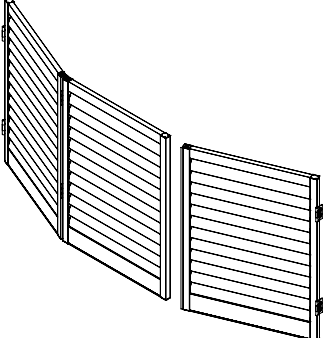
Drawing	Panel Configuration Code
	L - 1
	R - 1
	L-DR - 2
	LD-R - 2
	LL-DR - 3

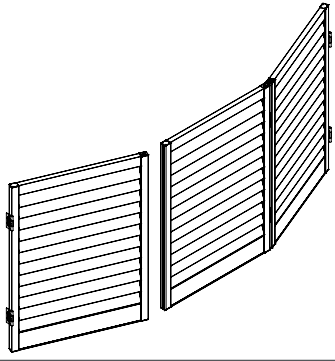
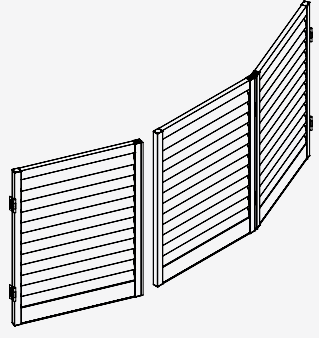
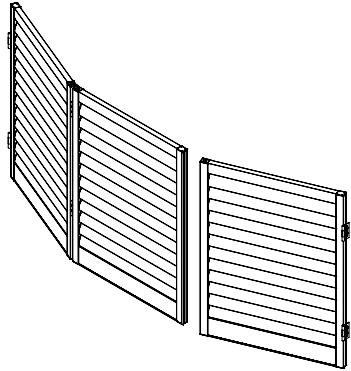
Drawing	Panel Configuration Code
	L-DRR - 3
	LD-RR - 3
	LLD-R - 3

Available Mounts - Reveal (In)

L = Left Hinged Panel
 R = Right Hinged Panel
 D = D-Mould

INSTALLATION METHOD: HINGED IN L OR Z FRAME

BEFORE YOU ORDER:

WARRANTY LIMITS

Installation Method	Width			Height			Panel Breaks	
	Min	Max	Max Non Warranty	Min	Max	Max Non Warranty	Mid-Rail(s) Required	Approximate Split Rotation by Blade Size
								89
Hinged IN Frame	200	1100	1200	400	3000	N/A	1500	1200
Double Hinged	200	500	600	400	2500	N/A	1500	1200

MINIMUM REVEAL DEPTH*

*Be sure to always measure from the most protruding object in the reveal.

Installation Method	Clearance 89mm Blade
L Frame	67
Z Frame	67

DEDUCTIONS

Panel and Reveal	Between Meeting Panels	Between Meeting Panels with D Mould	Between Panel and Frame	Between Frame and Reveal	Hinge Deductions	Overall Panel Deduction
2.5	2.5	5	2.5	2	2.5	5

HINGE COLOURS

Hinge Colour	Code
White	HB100
Ivory	HB103
Stainless Steel	HB201
Black	HB207

FLAT L 50MM FRAME

FLUSH MOUNT Z FRAME

Available Mounts - Reveal (In) and Face (Out)

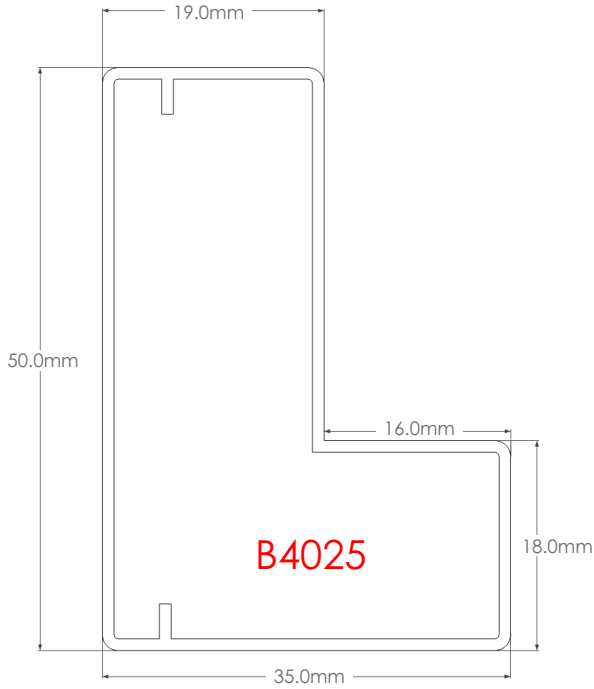

Available Mount - Reveal (In)

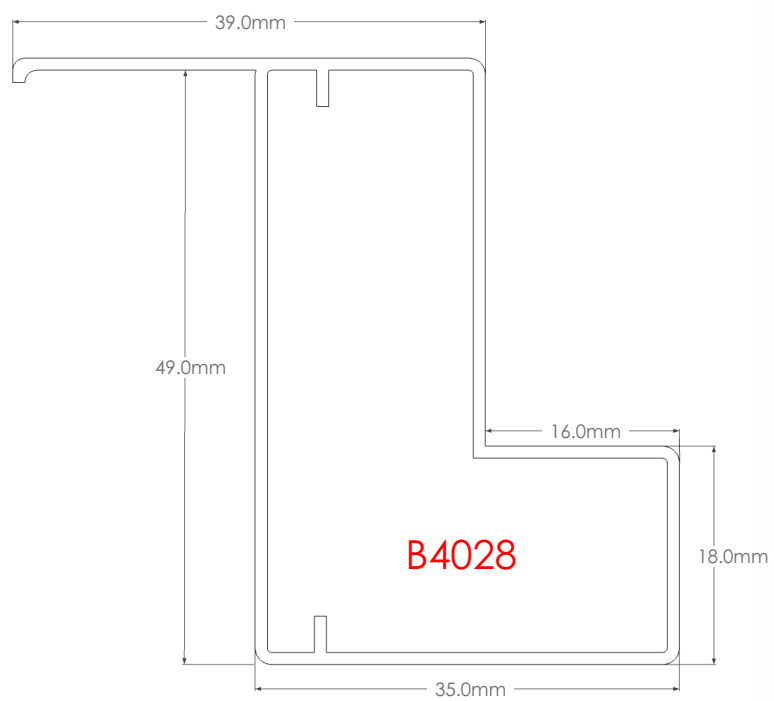

T POST

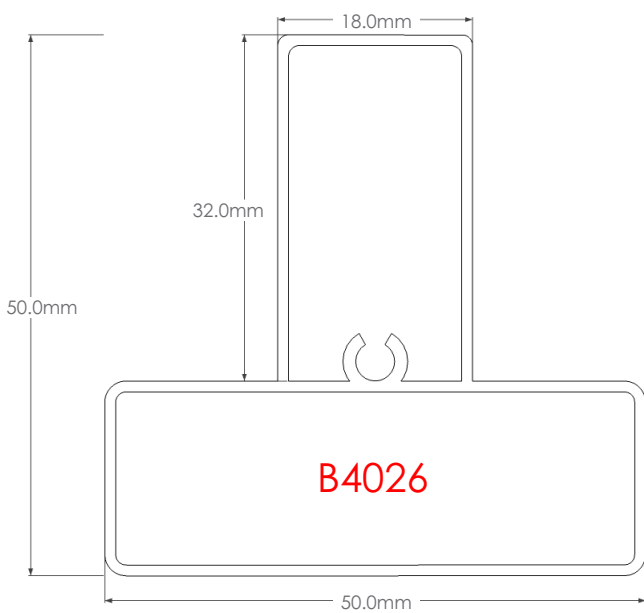

PANEL CONFIGURATIONS

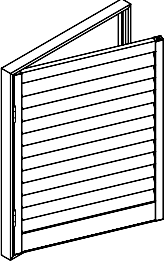
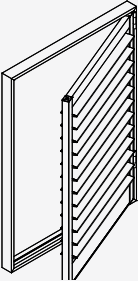
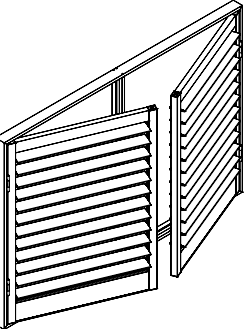
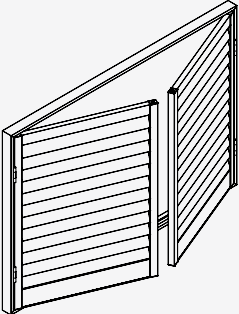
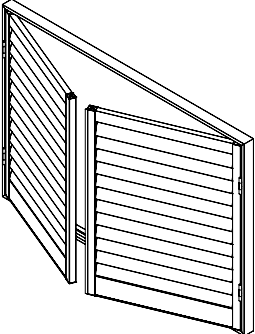
Drawing	Panel Configuration Code
	L - 1
	R - 1
	LTR - 2
	LR - 2
	L-DR - 2

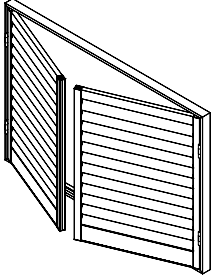
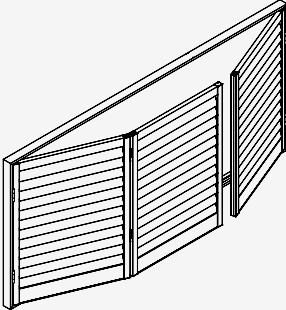
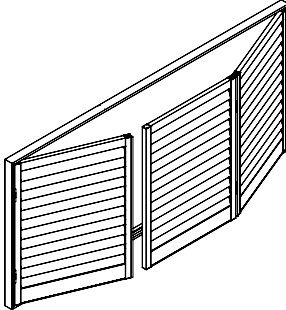
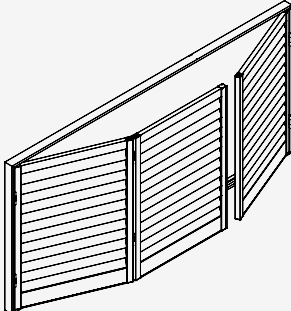
Drawing	Panel Configuration Code
	LD-R - 2
	LL-DR - 3
	LD-RR - 3
	LLD-R - 3

L = Left Hinged Panel
 R = Right Hinged Panel
 T = T-Post
 D = D Mould

FRAME BUILDOUT FOR L FRAME ONLY, ON OUTSIDE MOUNT

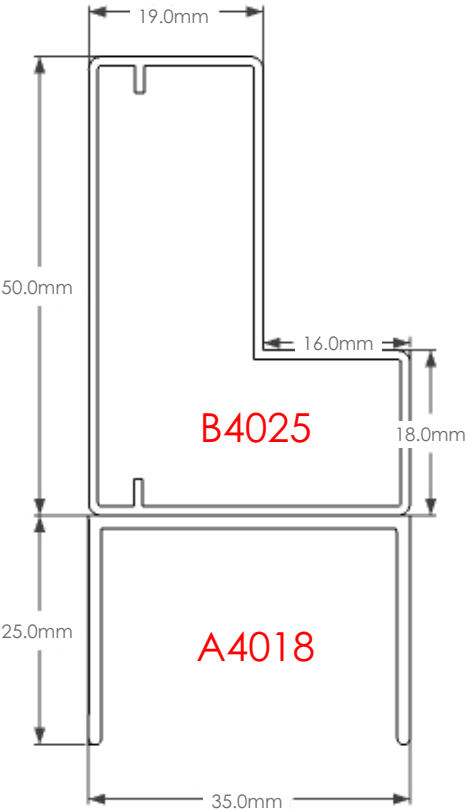

To allow for full rotation of blades on a outside mount L frame the following channel sizes can be added to the back of the frame.

89mm Blade = 25mm Channel

INSTALLATION METHOD: FIXED IN CHANNEL

BEFORE YOU ORDER:

WARRANTY LIMITS

Installation Method	Width			Height			Panel Breaks	
	Min	Max	Max Non Warranty	Min	Max	Max Non Warranty	Mid-Rail(s) Required	Approximate Split Rotation by Blade Size
								89
Fixed	200	1100	1200	400	3000	N/A	1500	1200

MINIMUM REVEAL DEPTH*

**Be sure to always measure from the most protruding object in the reveal.*

Installation Method	Clearance 89mm Blade
Fixed	67

DEDUCTIONS

Fixed Panel and Reveal	Between Meeting Panels	Overall Panel Deduction
2.5	2.5	5

TOP CHANNEL

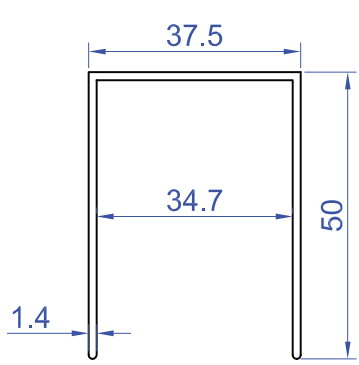

Used with H Section

A4015

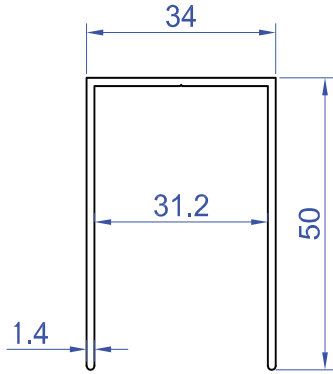

Used with No H Section

A4017

BOTTOM CHANNEL

Used with H Section

A4016

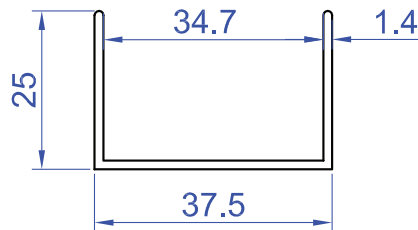

Used with No
H Section
Also used as Side
Channel

A4018

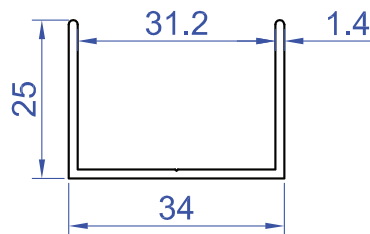

L ANGLE

25x25 angle is supplied when 'U Channel with Angle Front Only' is selected at ordering.

25x10 angle is supplied when 'U Channel with Angle Front & Back' is selected at ordering.

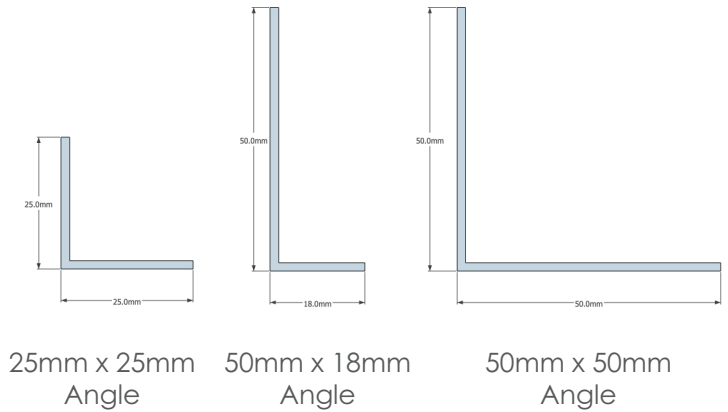
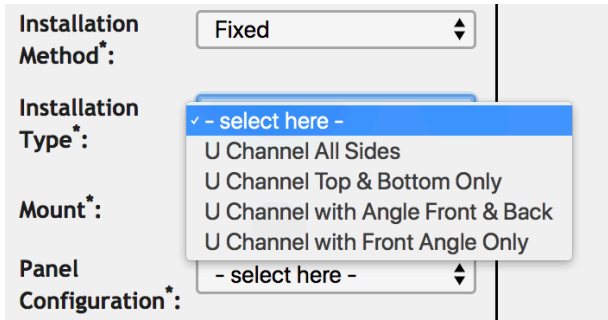

H SECTION & ANGLES

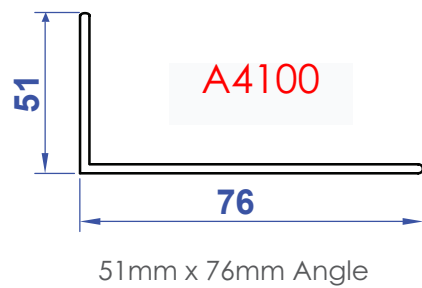
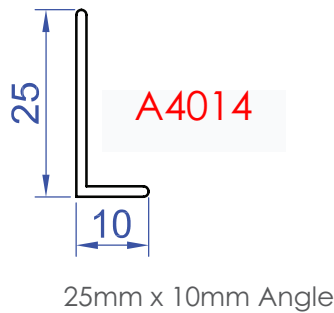
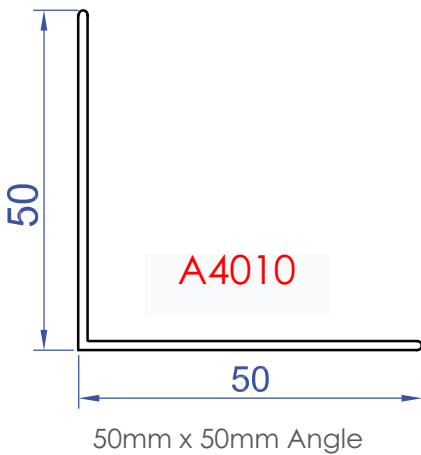
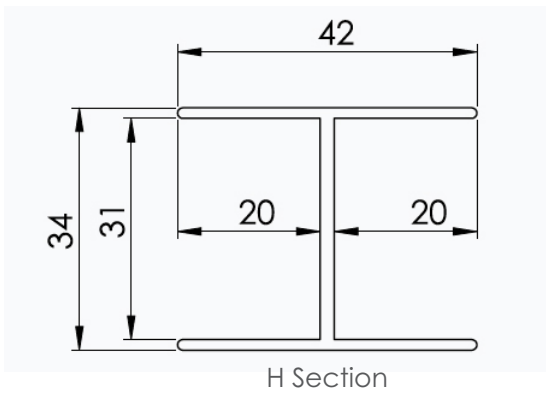

PANEL CONFIGURATIONS

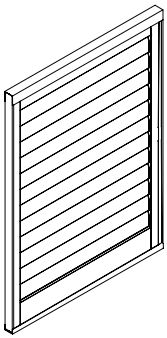
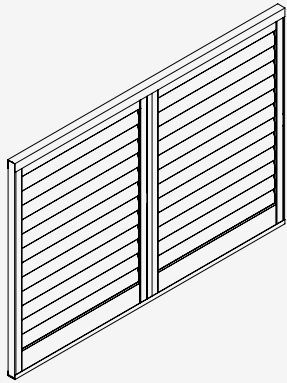
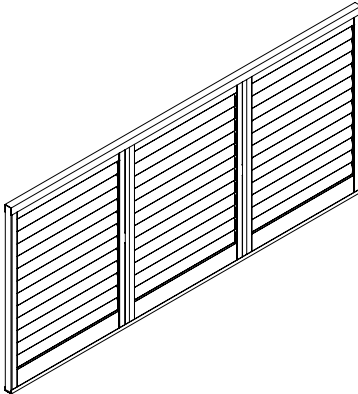
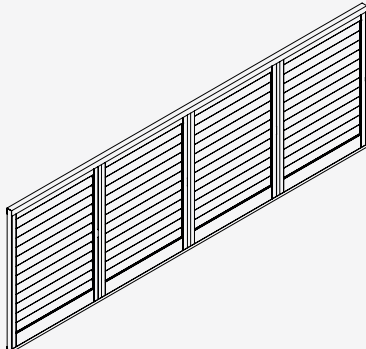
Drawing	Panel Configuration Code
	<p>F - 1</p>
	<p>FHF - 2</p>
	<p>FHFHF - 3</p>
	<p>FHFHFHF - 4</p>

Other Available Configurations:
 FHFHFHFHF - 5
 FHFHFHFHFHF - 6

Available Mounts - Reveal (In).

F = Fixed Panel
 H = H Section

INSTALLATION METHOD: SLIDING

BEFORE YOU ORDER:

WARRANTY LIMITS

Installation Method	Width			Height			Panel Breaks	
	Min	Max	Max Non Warranty	Min	Max	Max Non Warranty	Mid-Rail(s) Required	Approximate Split Rotation by Blade Size
								89
Sliding	200	1100	1200	400	3000	N/A	1500	1200

MINIMUM REVEAL DEPTH* **Be sure to always measure from the most protruding object in the reveal.*

Installation Method	Clearance 89mm Blade
2 Tracks Sliding, Blades Closed	108
2 Tracks Sliding, Blades Open	170

DEDUCTIONS

Top Track	Surface Mount Track	Bottom Track Recessed
52	20	10

INSTALLATION METHOD: SLIDING

HOW TO MEASURE & ORDER

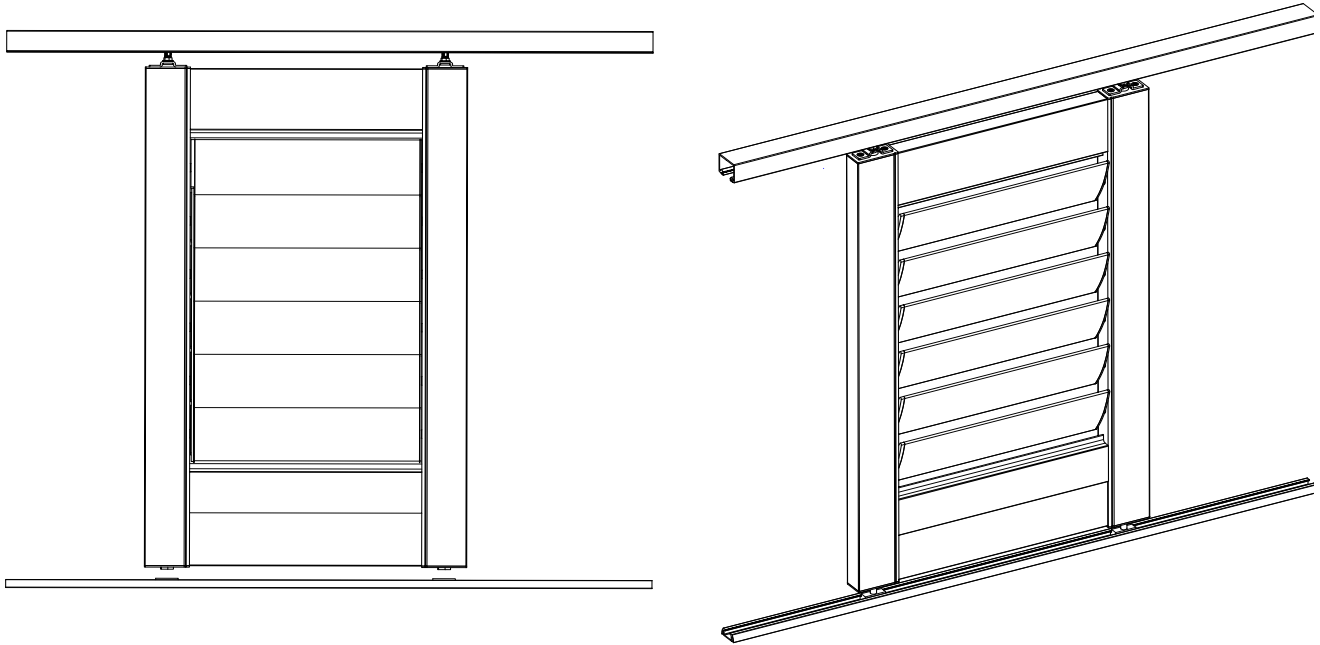

Choose the number of tracks you require: 1 Track, 2 Track(s)

Choose Reveal, Semi-Reveal or Face Mount.

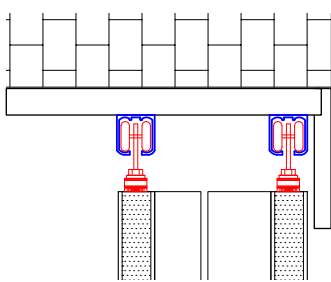

Reveal

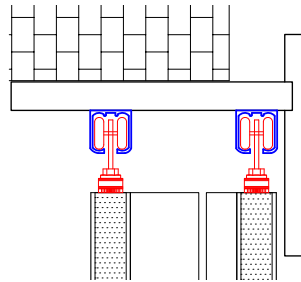

Semi-Reveal

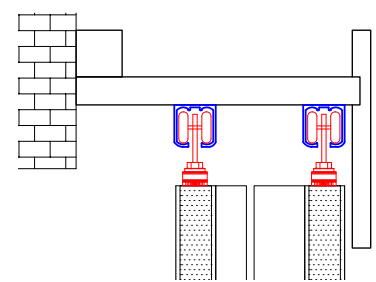

Face

Reveal Mount: Pelmet is fixed into the opening and the headboard is screwed up into the opening. The fascia will sit flush with the front of the opening and will not have returns.

Semi-Reveal Mount: Pelmet is fixed half in the opening and half out of the opening and the headboard is screwed up into the opening. A face mount and returns are supplied. The reveals will stop short of the width of the pelmet and hit the face of the opening.

Face Mount: Pelmet is fixed on to the outside of the opening, normally above the architrave. The headboard is attached using a 30x30 cleat. Fascia and full length returns are supplied.

TOP TRACK

HEADBOARD OPTIONS



7001

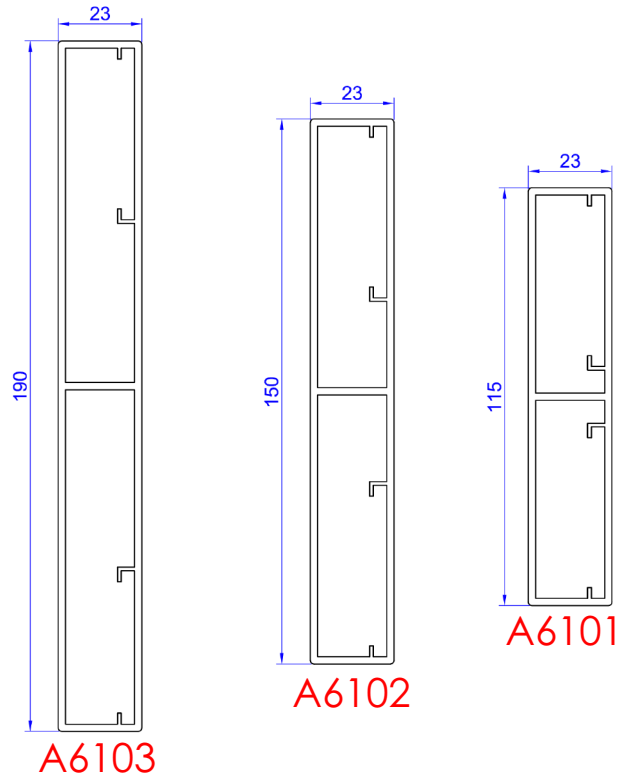

BOTTOM TRACK



7013

Bottom Track A

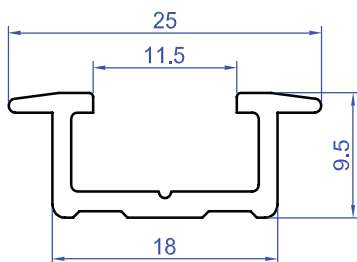

7014

Recessed Bottom Track

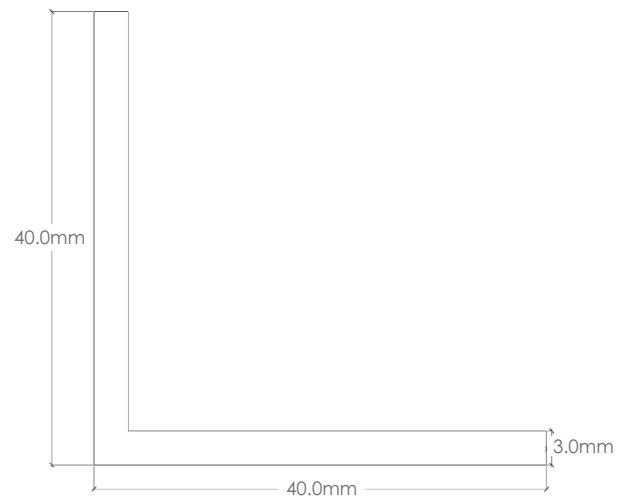

40x40 Angle supplied for fixing headboard.



Headboard brackets available in extras. Sizes 75mm, 100mm, 135mm, 180mm available.

PANEL CONFIGURATIONS

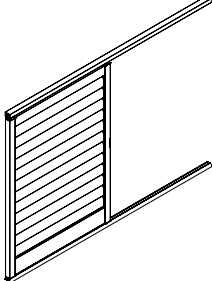
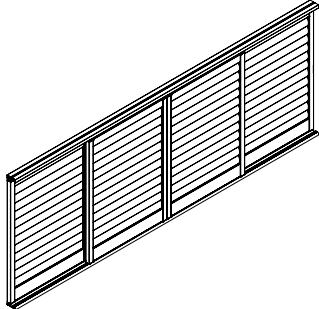
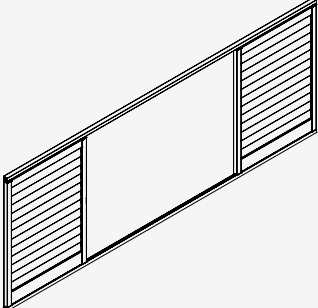
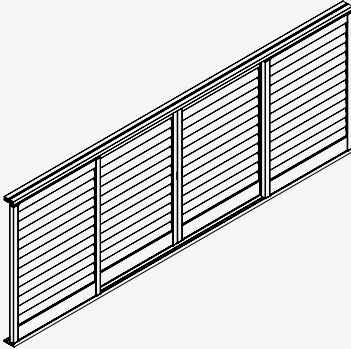
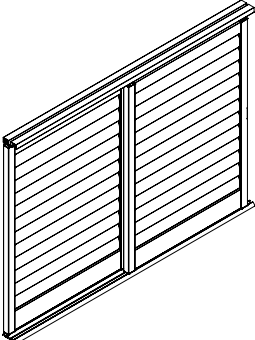
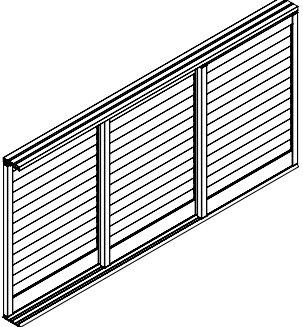
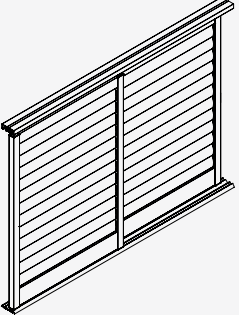
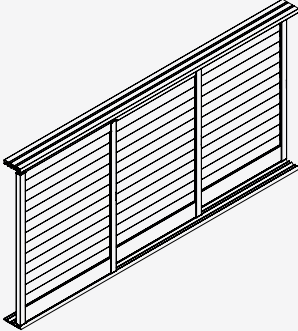
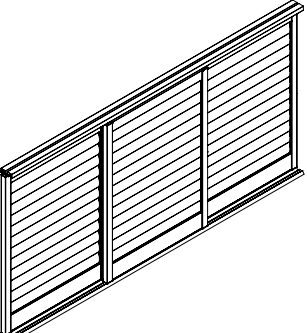
Drawing	Panel Configuration Code	Drawing	Panel Configuration Code
	1 Track S - 1		2 Tracks BFFB - 4
	1 Track SS - 2		2 Tracks FBBF - 4
	2 Tracks BF - 2		3 Tracks BMF - 3
	2 Tracks FB - 2		3 Tracks FMB - 3
	2 Tracks BFB - 3	<p>Other Available Configurations:</p> <ul style="list-style-type: none"> BFFBFB - 6 (2 Tracks) BMFFMB - 6 (3 Tracks) FMBBMF - 6 (3 Tracks) <p>S = Single Sliding Panel B = Back Sliding Panel F = Front Sliding Panel M = Middle Sliding Panel</p>	

INSTALLATION METHOD: MULTI-FOLD

BEFORE YOU ORDER:

WARRANTY LIMITS

Installation Method	Width			Height			Panel Breaks	
	Min	Max	Max Non Warranty	Min	Max	Max Non Warranty	Mid-Rail(s) Required	Approximate Split Rotation by Blade Size
								89
Multi-Fold	200	500	600	400	3000	N/A	1500	1200

MINIMUM REVEAL DEPTH*

*Be sure to always measure from the most protruding object in the reveal.

Installation Method	Clearance 89mm Blade
Multi-Fold	67

DEDUCTIONS

Top Track	Bottom Track	Bottom Track Recessed	Bottom Multi-Fold Pivot Height	Bottom Multi-Fold Pivot Width
52	20	28	20	5

INSTALLATION METHOD: MULTI-FOLD

HOW TO MEASURE & ORDER

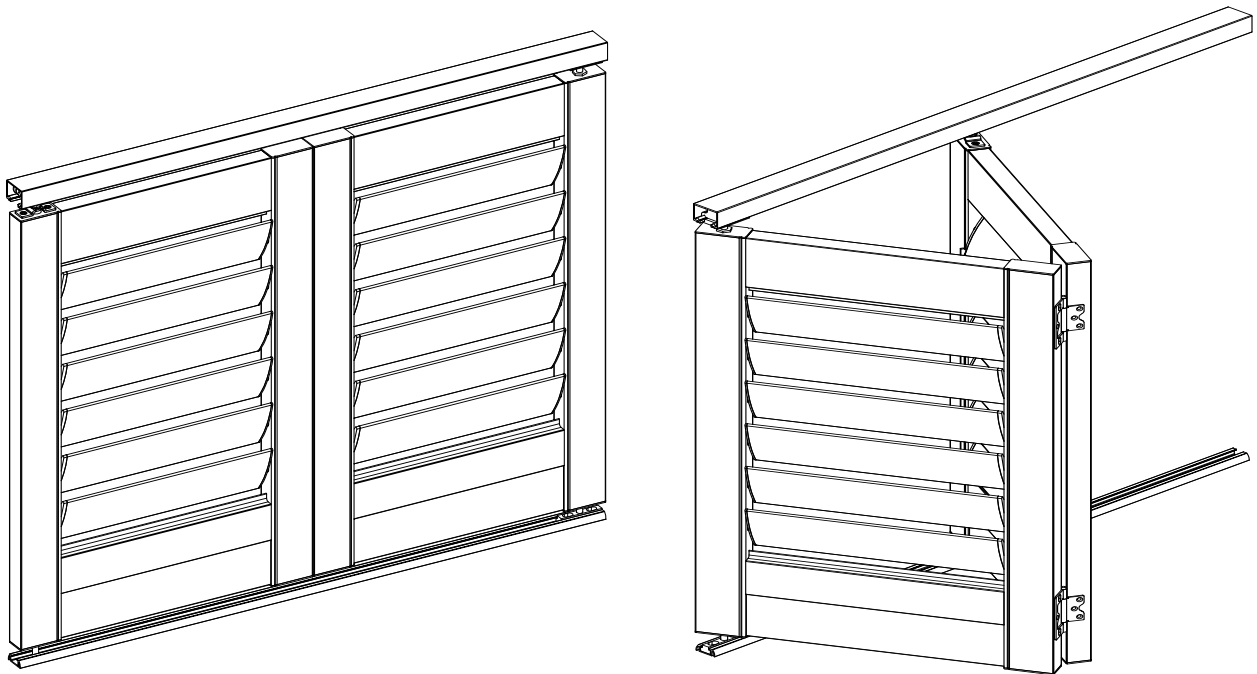

Installation Type: Choose the folding pattern of the panels, either Standard Fold or Reverse Fold.

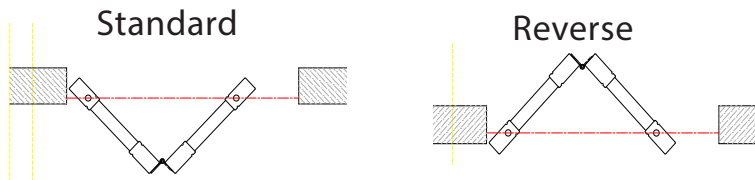

Mount: Select either Face (Out) or Reveal (In)

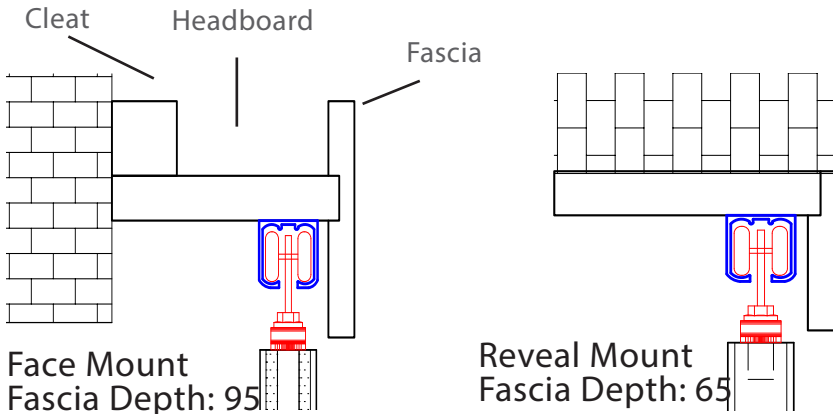

Warranty Note: The maximum number of panels folding in one direction is four. Panel configurations are to be an even numbers and move in pairs. This ensures that each panel is able to be secured in the opening.

TOP TRACK

HEADBOARD OPTIONS



7001

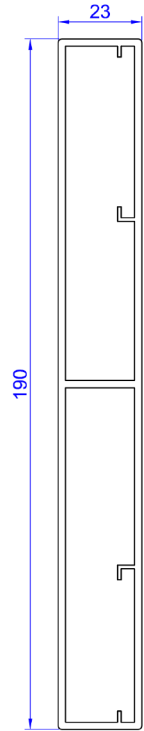

A6103

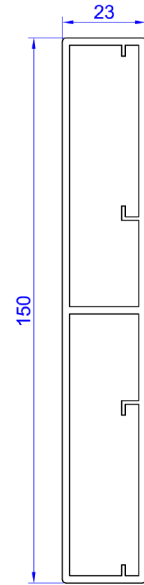

A6102

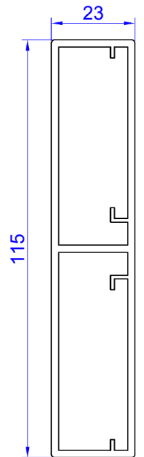

A6101

BOTTOM TRACK



7013

Bottom Track A

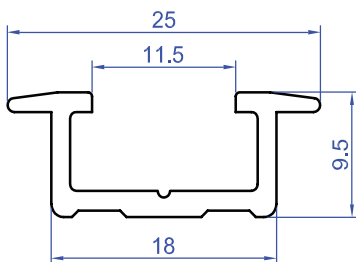

7014

Recessed Bottom Track

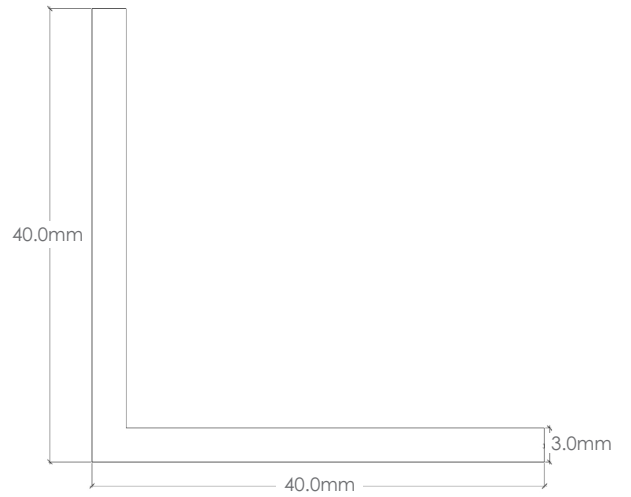

40x40 Angle supplied for fixing headboard.



Headboard brackets available in extras. Sizes 75mm, 100mm, 135mm, 180mm available.

PANEL CONFIGURATIONS – STANDARD FOLD

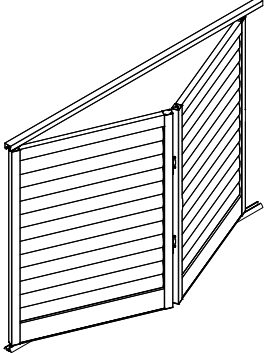
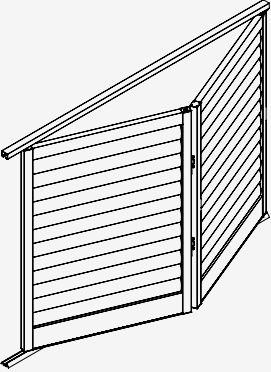
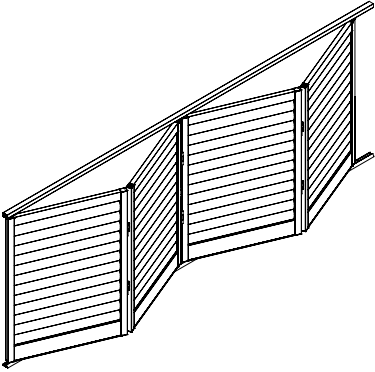
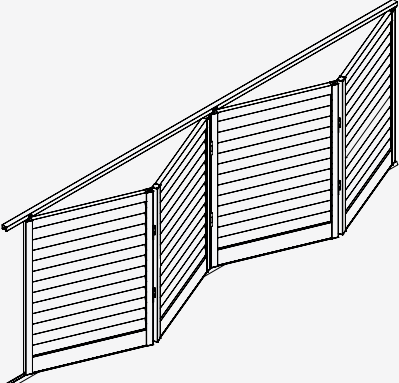
Drawing	Panel Configuration Code
	LL - 2
	RR- 2
	LLLL - 4
	RRRR - 4

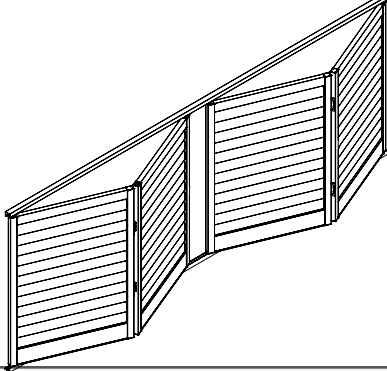
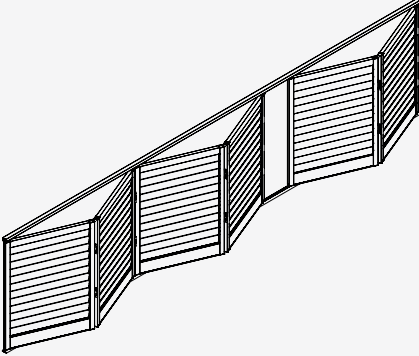
Drawing	Panel Configuration Code
	LLRR - 4
	LLLLRR - 6

Important Note:

The maximum number of panels folding in one direction is four.

Panel configurations are to be an even numbers and move in pairs. This ensures that each panel is able to be secured in the opening.

L = Left Multi-Fold Panel
R = R Multi-Fold Panel

PANEL CONFIGURATIONS – REVERSE FOLD

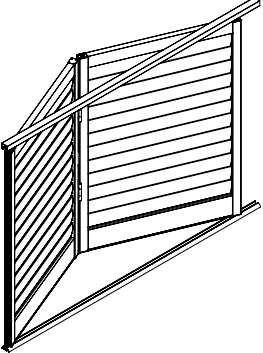
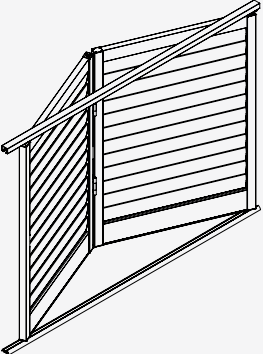
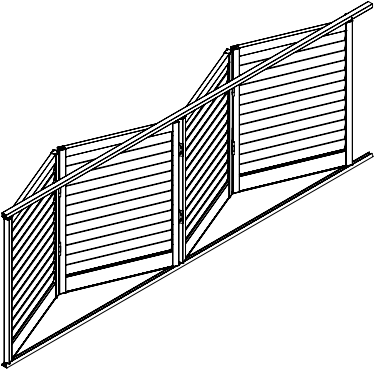
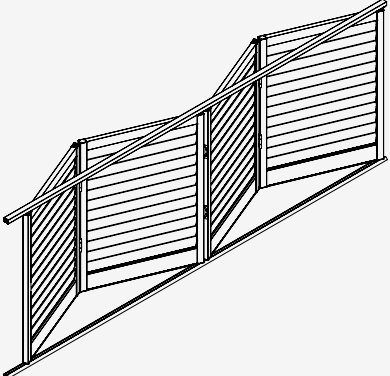
Drawing	Panel Configuration Code
	LL - 2
	RR - 2
	LLLL - 4
	RRRR - 4

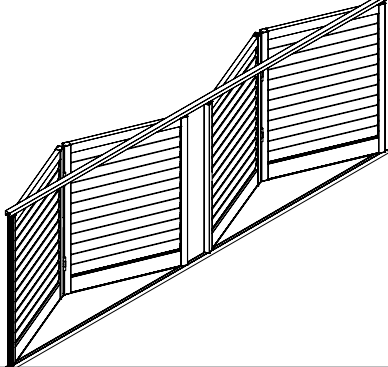
Drawing	Panel Configuration Code
	LLRR - 4

Important Note:

The maximum number of panels folding in one direction is four.

Panel configurations are to be an even numbers and move in pairs. This ensures that each panel is able to be secured in the opening.

Other Available Configurations:
 LLLLRR - 6
 LLRRRR - 6

L = Left Multi-Fold Panel
 R = R Multi-Fold Panel

PRE-DRILLING OF FRAMES

If requested in Special Instructions, the factory will pre-drill countersunk holes as per the following guideline:

- A) On the left and right frame 250mm from the corner a hole will be drilled.
- B) If the left and right frame length is greater than 2500mm, an additional hole will be drilled at the mid point on each side.
- C) If the top and bottom frame length is greater than 1000mm a hole will be drilled at the mid point also.

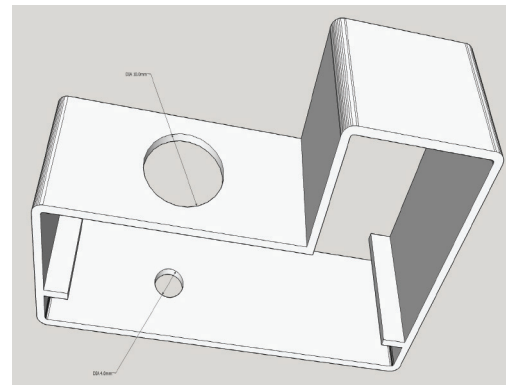
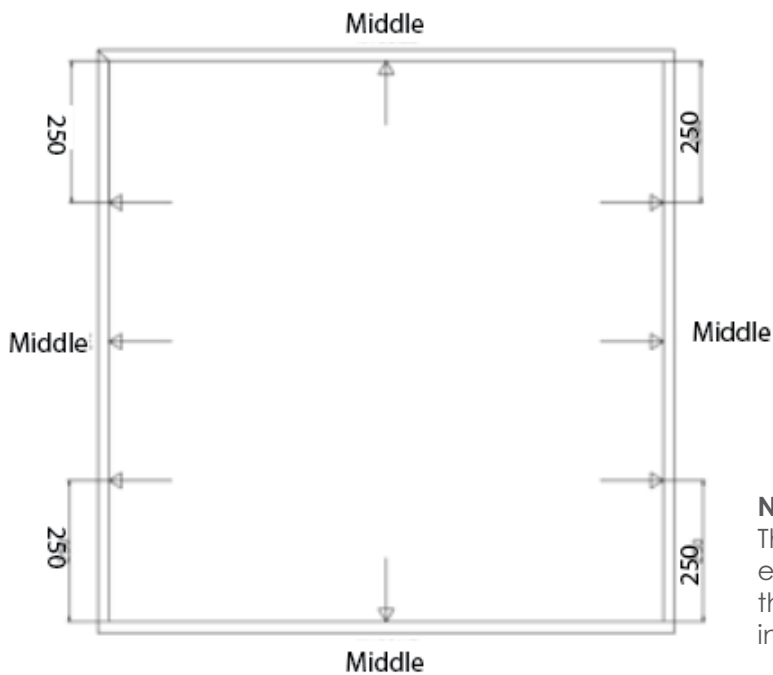

Note:

The first drill hole will be 10mm in diameter and a cap will be supplied to hide the screw. The second hole will be 4mm in diameter for the screw fixing.

EXTRAS:

FLY SCREEN UNIT – FIBERGLASS

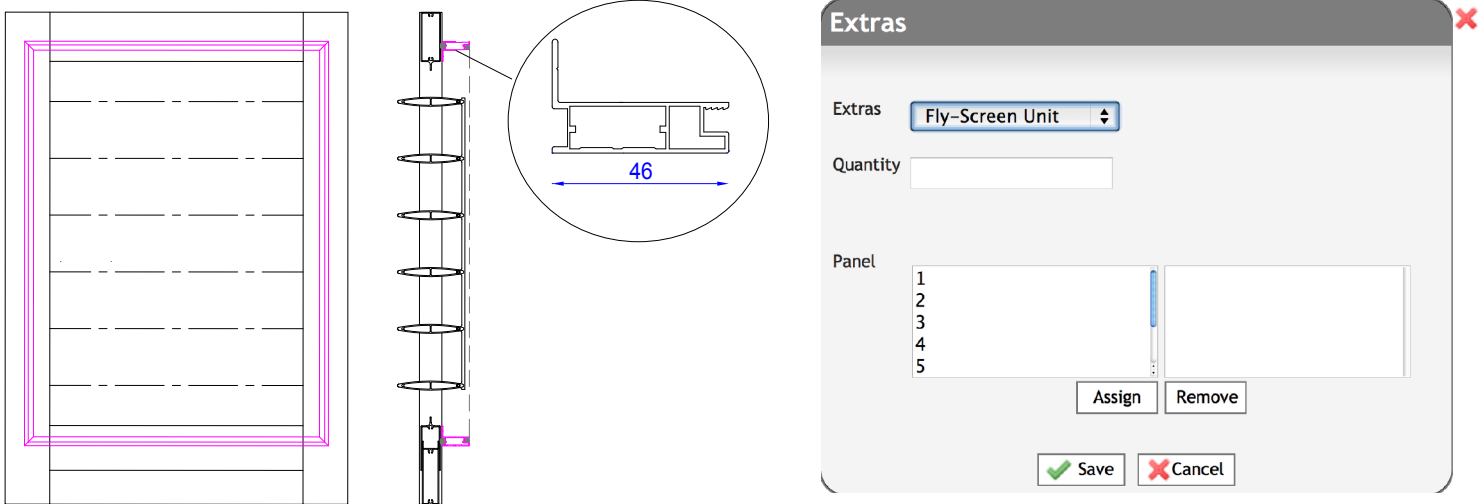

Available Installation Methods:

Hinged in Frame, Fixed.

Available Colours:

Black

FLY SCREEN UNIT – ALUMINIUM MESH A9003

Available Colours:

Black

Installation Type:

Currently only available for a Fixed in Top and Bottom U Channel installation type.

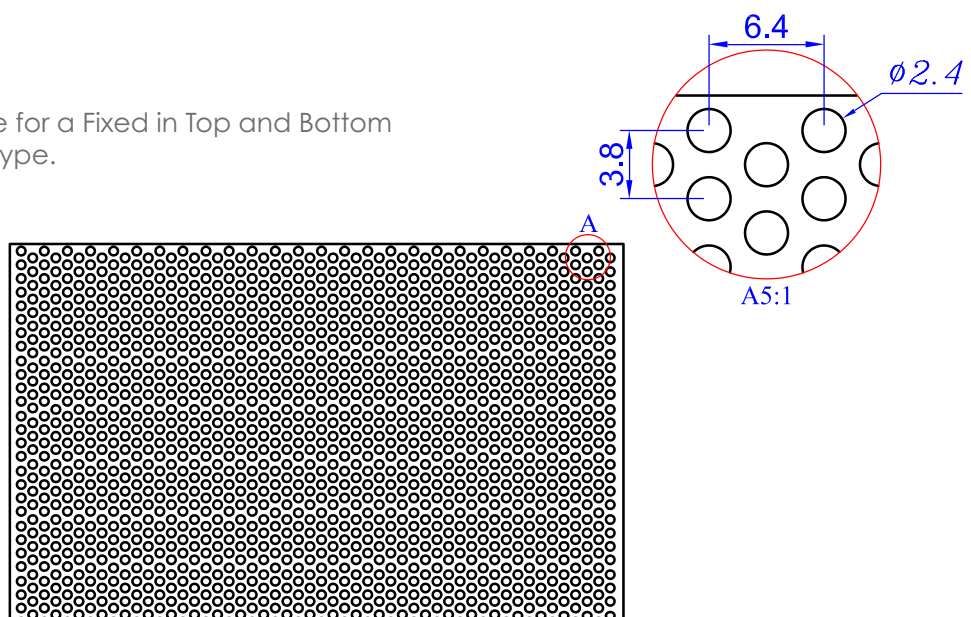

EXTRAS:

DOUBLE SHOOT BOLT **A9003**



Available Installation Methods:

Hinged no Frame and Hinged in Frame

Important Note:

Available with a key lock only. Note: All openings will be keyed alike as standard for each order.

Double Shoot Bolt default position is centre unless specified in notes.

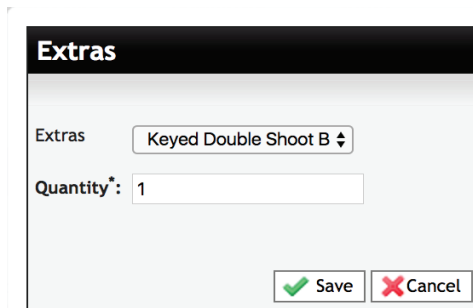

FLUSH BOLT

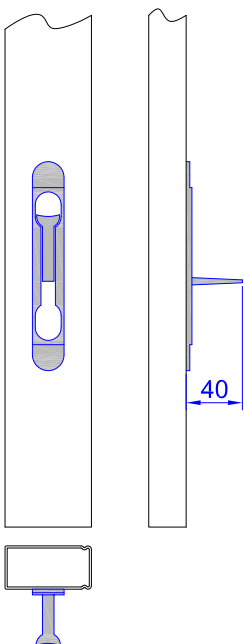

Available Installation Methods:

Hinged in Frame
Hinged No Frame
Multi-Fold (bottom only)

Important Note:

Flush bolts can not be fitted to the section of the panels where the hardware is attached to the tracking system.

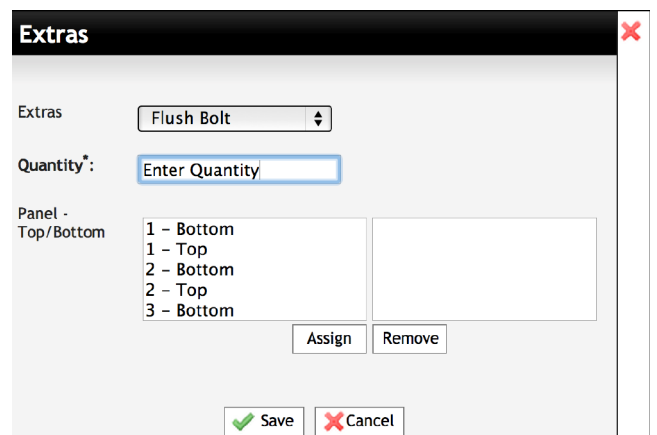

EXTRAS:

UNIVERSAL PULL STICK

Open shutter blades with ease in out of reach installations for light adjustment.
Available in White.

HOW TO ORDER:

Select from the *Extras* drop-down menu.



BLADE STAY

Available Colours: Black, White

Important Note:

A Blade Stay is required every 1300mm or where a split rotation is required. Max panel height is 1800mm and will require 2 x Blade Stays.

If a panel has a mid-rail, a Blade Stay will be required both above and below the mid-rail to operate each section independently.

Positioning: If uneven number of blades, it will default to one blade below centre of section of blades.

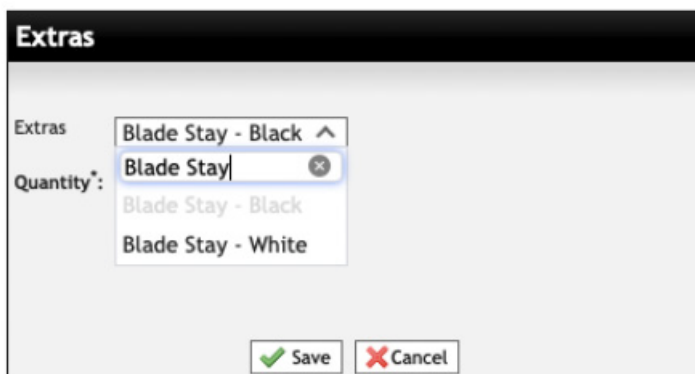

EXTRAS:

CUPBOARD CATCH

Designed to hold firmly and prevent doors swinging open during windy conditions. The catch is made from plastic and installed with a stainless steel screw (rust proof). No surcharge applicable.

HOW TO ORDER:

When placing your order, please select *Cupboard Catch* from the *Extras drop-down*. This option will be supplied loose in order to prevent damage in transit.



COLOUR MATCH STICKERS

Colour match stickers are available for custom colour jobs. Surcharge applies.



SHELF BRACKET

Available in Mill (colour).

HOW TO ORDER:

Order under *Extras* with your specified width requirements.

IMPORTANT NOTE

The opening has to increase by 40mm in height.

Measurement is to the bottom of the headboard as a standard face fit opening.

It is up to the dealer to provide the measurement to the underside of the headboard increasing the height of the opening by a minimum of 40mm.

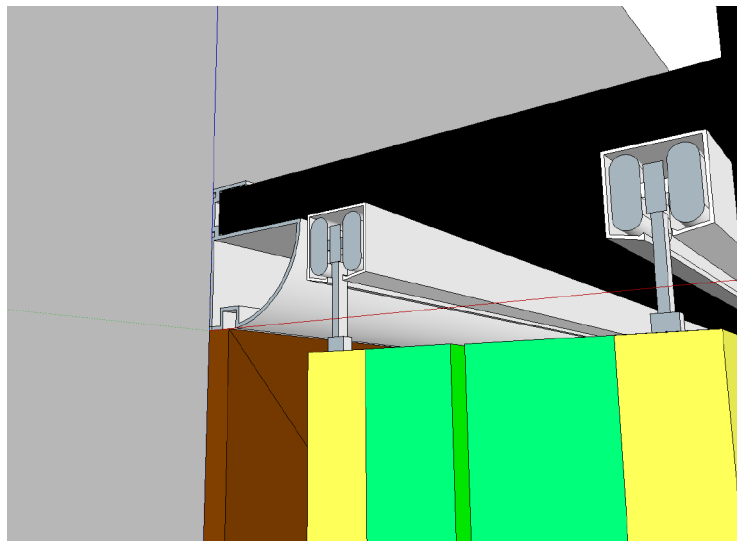
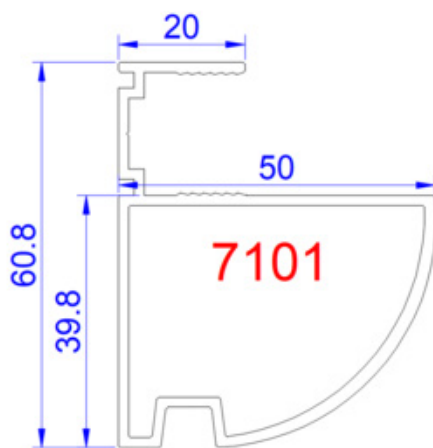

SPECIAL INSTRUCTIONS

10mm Door Clearance - The factory will take an additional 10mm deduction off the height of the opening to allow for clearance in doors.

B-Folding Panels - Multiple panels are hinged together off the one side of the opening with no top or bottom track. For hinged in Frame and Hinged No Frame installation methods only.

Hinges Loose - Hinges for the line item will be supplied loose in the components box and not attached to the panels.

Internal Installation Required - Shutters will be installed inside a home or commercial building, not in an external application.

Magnets Loose - Magnets will be supplied loose in the components box and not attached to the panels.

Tier on Tier - Shutters in a Hinged in Frame installation method will be installed as two stacks, one on top of the other. Shutters in each section are able to operate independently of each other. A horizontal t-post may be required for openings over a specific, please confirm with the factory.

Pre-Drill Frames - Upon request factory will countersink holes in the frame. The first drill hole will be 10mm in diameter and a cap will be supplied to hide the screws. The second hole will be 4mm in diameter for the screw fixing.