

V.05.04.24



STANDARD PRODUCT GUIDE: METRIC



TWO GUIDELINES

Orders that are released to TWO are processed in the most timely manner possible. As such, any changes made to an order once it is released to TWO cannot be guaranteed to be applied if the order is already in production. Initial costs, cancellations or any change costs will be the responsibility of the dealer to cover.

All drawings, notes and emails with questions must be answered before an order is entered in to the production line. Delays in the timely processing of these by customers will lead to longer lead times.

All factory/freight repairs are to have photographic/video proof. If neither are available at the time of placing the repair, it will be processed as a dealer responsibility. TWO will credit back the cost of the repair once proof of factory/freight responsibility is given.

For special request/non-standard/limited availability items please check first with Head Office for availability. Any surcharges for these items will be the responsibility of the dealer to cover, even if it is not listed on the price list.

PDF Estimates generated from the system may not reflect final pricing. If all items are not selected in the order form, or details are added to the notes section that may alter the price.

All dealers are responsible for having the most current price lists and product manuals. If unsure please contact your sales representative to confirm.

COLOUR OPTIONS

There are four standard powdercoat finishes (40% sheen) along with four timber wraps which offer the look of the traditional timber shutter, with the durability of aluminum.

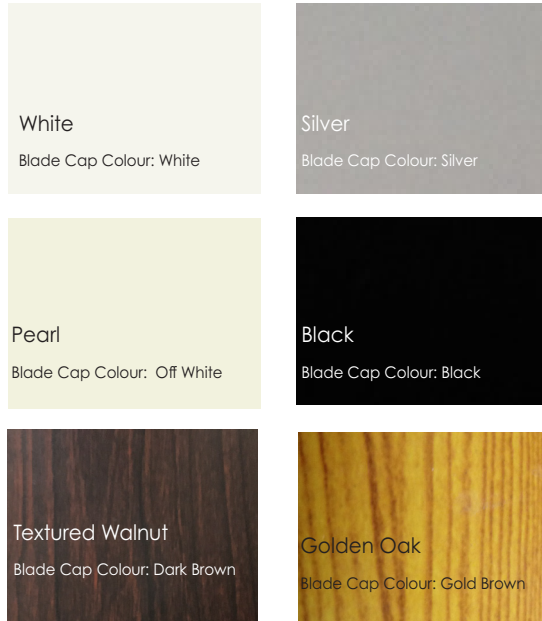

CUSTOM COLOUR FINISH

Choose from one of the many colours offered by Duralloy Dulux. Please be sure to select from the below pictured specifier for accurate colour matching "to deck".

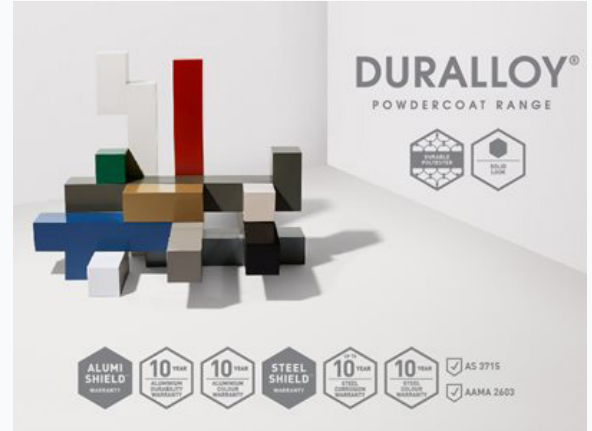

Please Note: Custom colour finishes are applied as a powdercoat. Blade end caps will be colour matched to the custom colour selected.

Powdercoat finishes will be applied with a standard satin finish at 40% sheen. For custom sheen finishes e.g. matte or gloss, surcharges will apply. Metallic finishes not available.

BLADES

Available in three blade sizes - 64mm, 89mm, and 114mm. Blade end caps are solid.

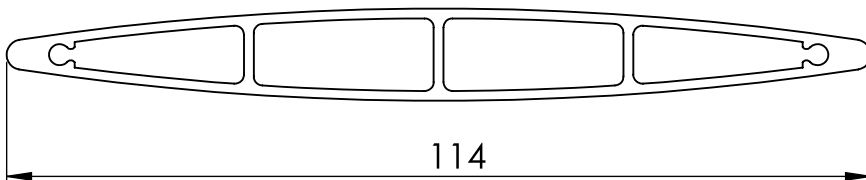
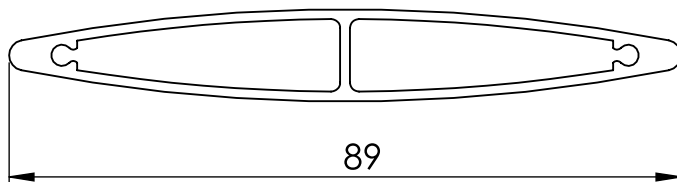
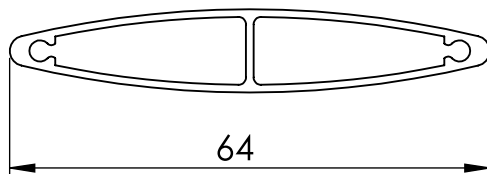

STILE

This product range offers a 60mm beaded stile.

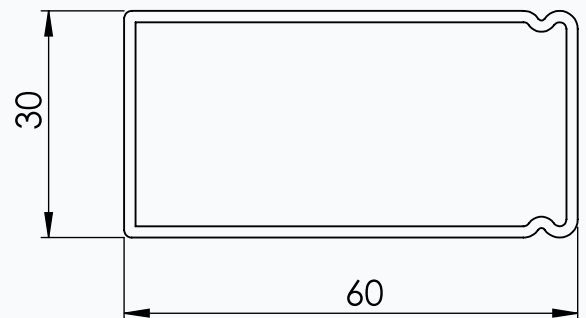

BOTTOM, MID & TOP RAILS

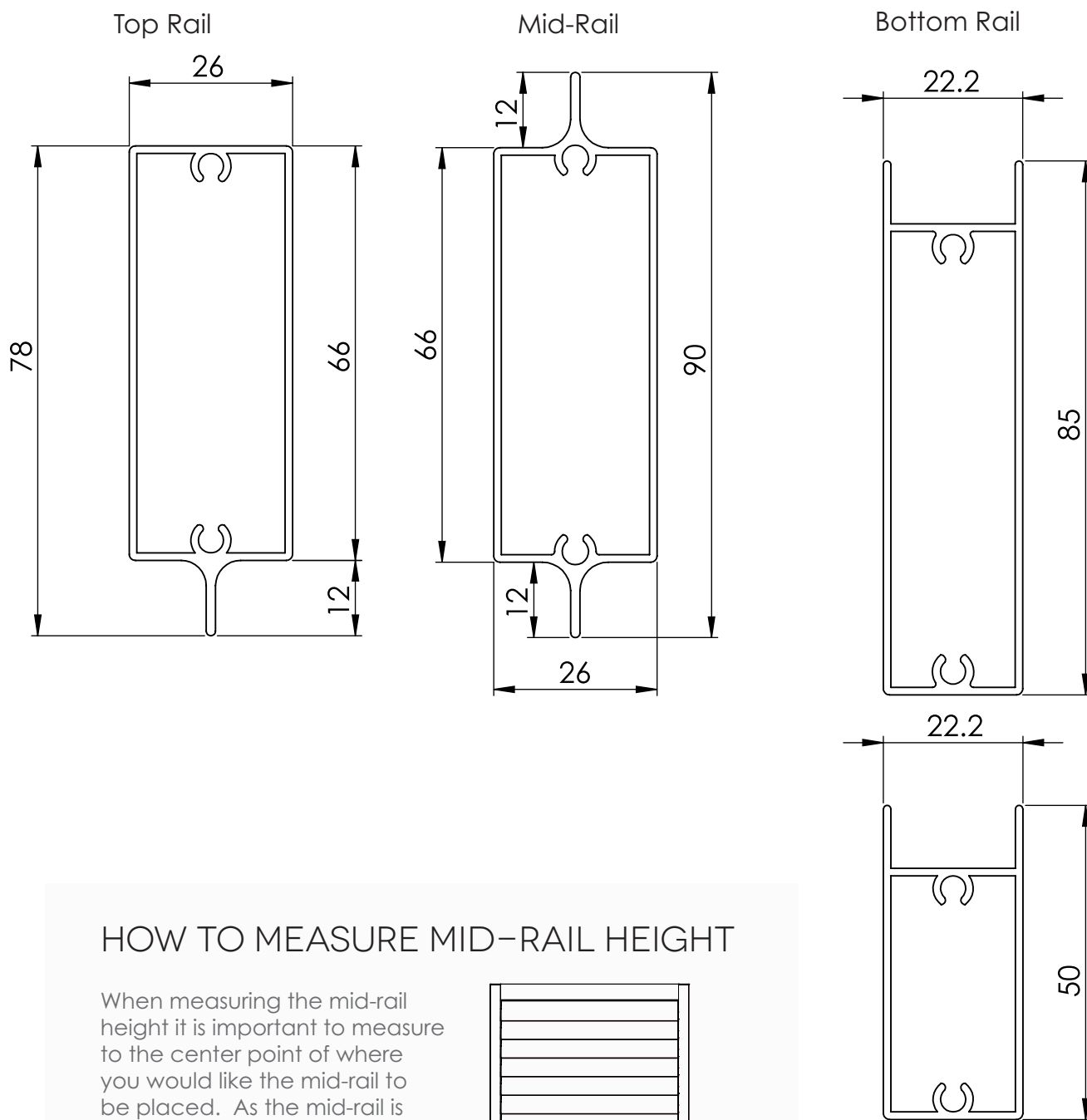

HOW TO MEASURE MID-RAIL HEIGHT

When measuring the mid-rail height it is important to measure to the center point of where you would like the mid-rail to be placed. As the mid-rail is the same size as an individual blade, it will be placed approximately +/- 25mm for the specified height.

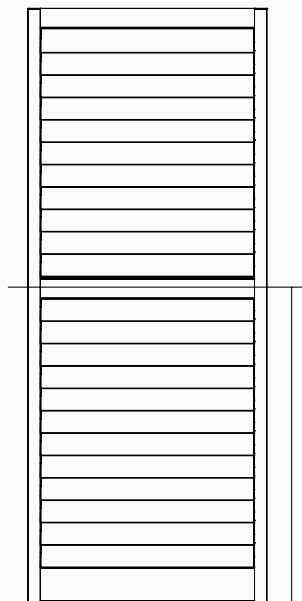

HOW TO MEASURE

REVEAL (IN) MOUNT

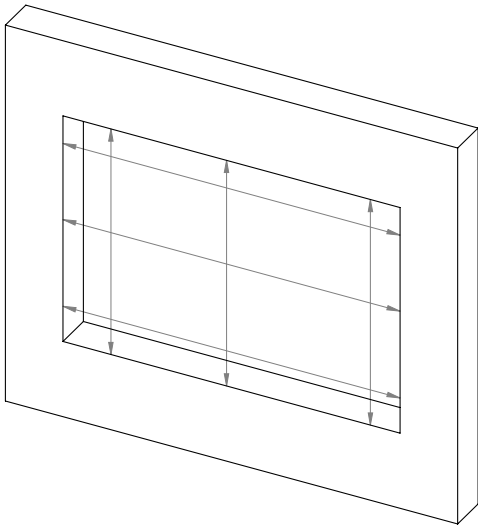

Width Points of Measure:
Top, Center and Bottom

Height Points of Measure:
Left, Center and Right

For Reveal openings, enter the smallest width and height of the measurements taken. All standard deductions will be taken for the units to fit inside the opening.

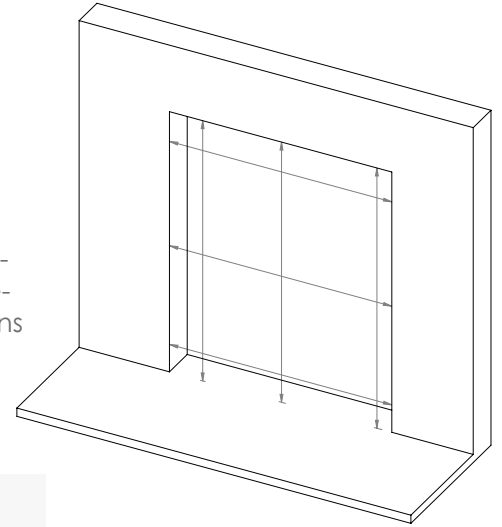

MEASURING TIP:

Always measure your opening from left to right.

FACE (OUT) MOUNT

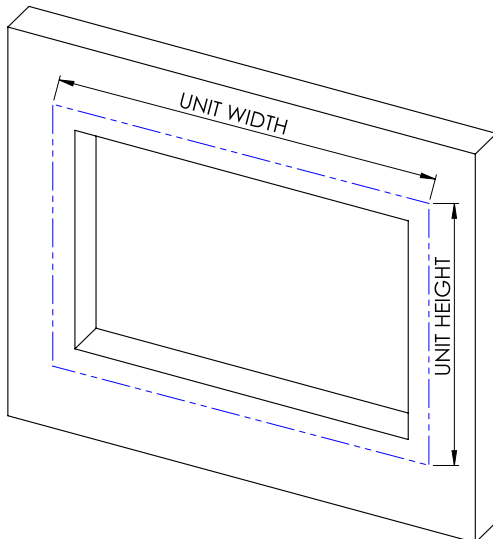

Width Points of Measure:
From the left to the right of the opening

Height Points of Measure:
From the top to the bottom of the opening

For Face Mount openings enter the width and height of the opening. No deductions will be taken. The measurements given will be from edge to edge including the frame.

SUB-WIDTHS: HOW TO MEASURE

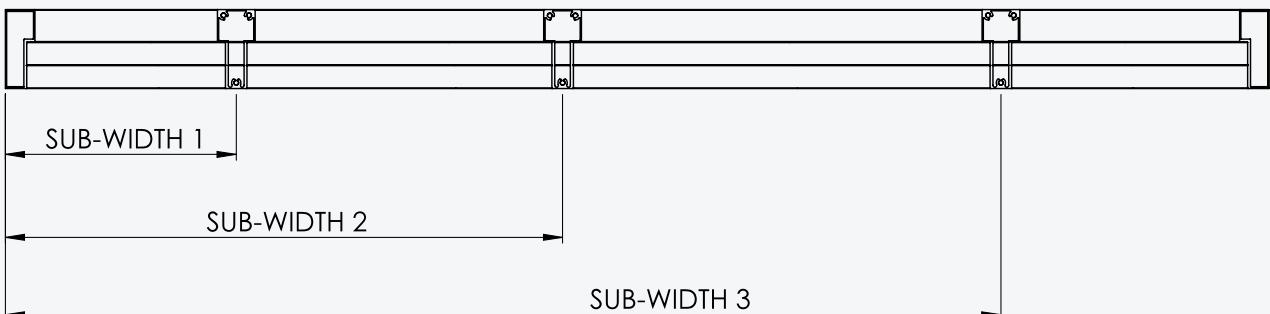

INSTALLATION METHOD: HINGED NO FRAME



BEFORE YOU ORDER:

WARRANTY LIMITS

Installation Method	Width			Height			Mid-Rail(s) Required	Panel Breaks		
	Min	Max	Max Non Warranty	Min	Max	Max Non Warranty		Approximate Split Rotation by Blade Size*		
								64	89	114
Hinged No Frame	200	900	950	400	3400	N/A	2000, 3000	1000/ 20 Blades	1200/ 13 Blades	1200/ 10 Blades
Double Hinged	200	400	450	400	3400	N/A	2000, 3000			

*** Important Note:**

The factory will automatically split the rotation if the size exceeds factory standards as noted above.

DEDUCTIONS

Panel and Reveal	Between Meeting Panels	Between Meeting Panels with D Mould	Hinge Deductions	Overall Panel Deduction for Non-Mortise Hinged
2.5	2.5	5	2.5	5

PANEL CONFIGURATIONS

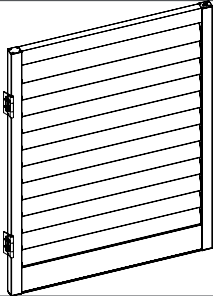
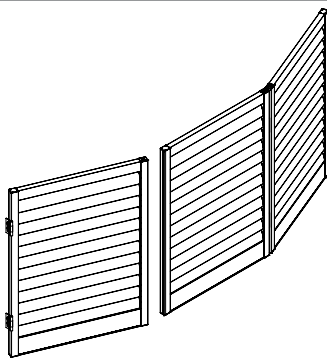
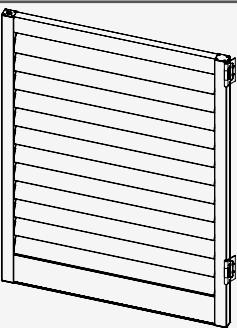
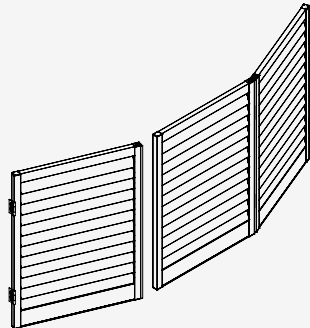
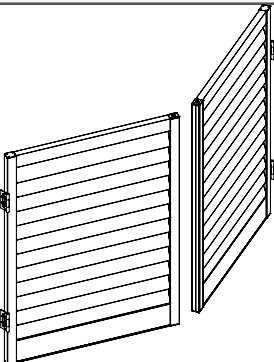
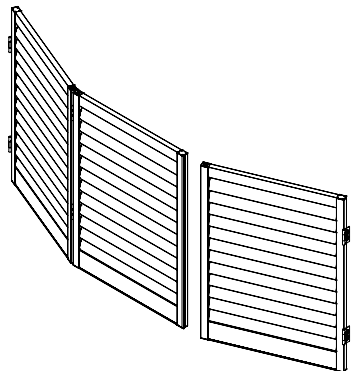
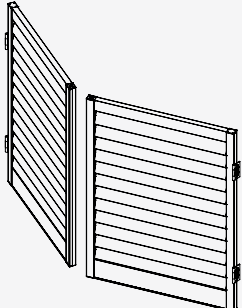
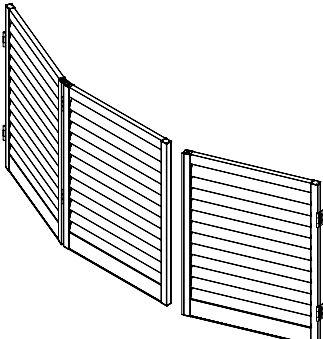
Drawing	Panel Configuration Code	Drawing	Panel Configuration Code
	L - 1		L-DRR - 3
	R - 1		LD-RR - 3
	L-DR - 2		LLD-R - 3
	LD-R - 2		
	LL-DR - 3		

Available Mounts - Reveal (In)

INSTALLATION METHOD: HINGED IN L OR Z FRAME



BEFORE YOU ORDER:

WARRANTY LIMITS

Installation Method	Width			Height			Mid-Rail(s) Required	Panel Breaks		
	Min	Max	Max Non Warranty	Min	Max	Max Non Warranty		Approximate Split Rotation by Blade Size*		
								64	89	114
Hinged IN Frame	200	900	950	400	3400	N/A	2000, 3000	1000/ 20 Blades	1200/ 13 Blades	1200/ 10 Blades
Double Hinged	200	400	450	400	3400	N/A	2000, 3000			

*** Important Note:**

The factory will automatically split the rotation if the size exceeds factory standards as noted above.

MINIMUM REVEAL DEPTH*

*Be sure to always measure from the most protruding object in the reveal.

Installation Method	Clearance 64mm Blade	Clearance 89mm Blade	Clearance 114mm Blade
L Frame	54	67	79
Z Frame	38	51	64

DEDUCTIONS

Panel and Reveal	Between Meeting Panels	Between Meeting Panels with D Mould	Between Panel and Frame	Between Frame and Reveal	Hinge Deductions	Overall Panel Deduction
2.5	2.5	5	2.5	2	2.5	5

FLAT L 50MM FRAME

Available Mounts - Reveal (In) and Face (Out)

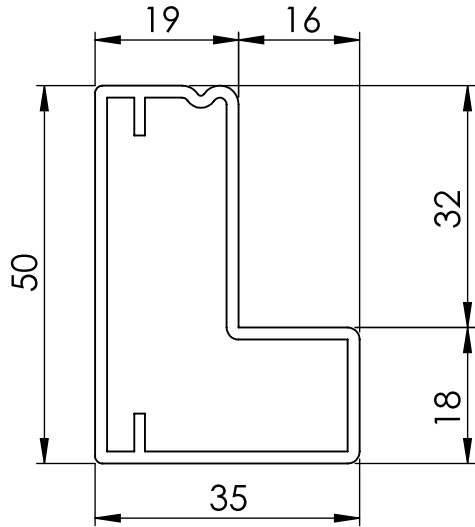

Important Note:

Max Length is 6000mm. For lengths greater than 6000mm, frames will be cut in half or joined at an intersecting point in the frame.

FLUSH MOUNT Z FRAME

Available Mount - Reveal (In)

NOTE: This frame is only available in the finishes - white, pearl, black, silver and textured walnut.

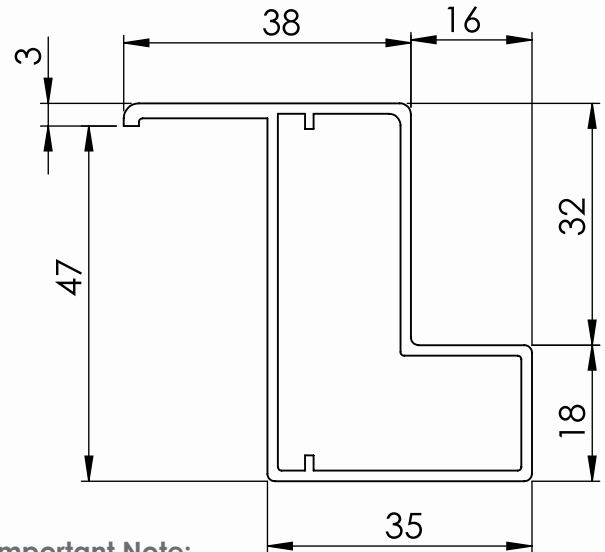

Important Note:

Max Length is 6000mm. For lengths greater than 6000mm, frames will be cut in half or joined at an intersecting point in the frame.

T POST

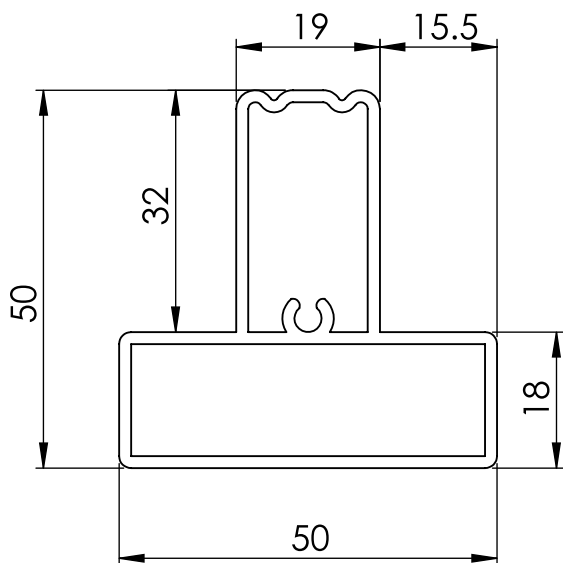

STANDARD Z FRAME

Available Mount - Reveal (In)

NOTE: This frame is not available in timber wrap colours.

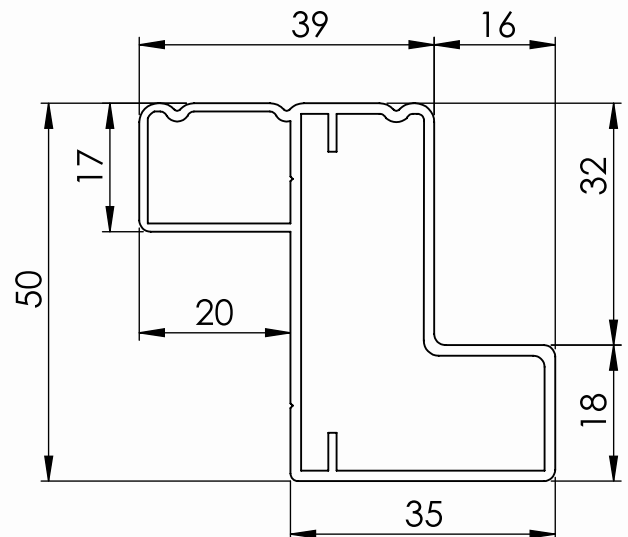

Important Note:

Max Length is 6000mm. For lengths greater than 6000mm, frames will be cut in half or joined at an intersecting point in the frame.

PANEL CONFIGURATIONS

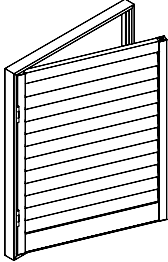
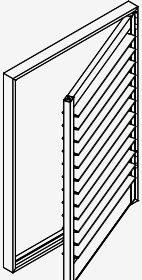
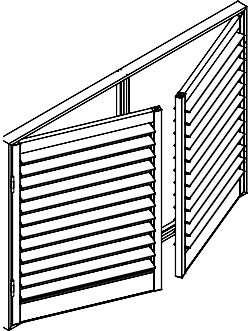
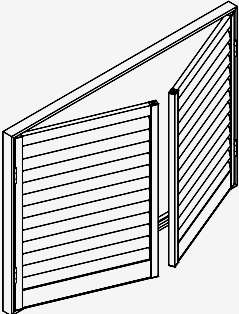
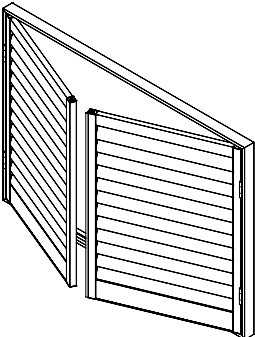
Drawing	Panel Configuration Code
	L - 1
	R - 1
	LTR - 2
	LR - 2
	L-DR - 2

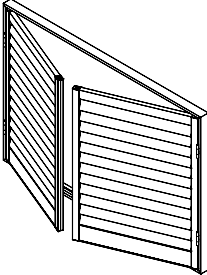
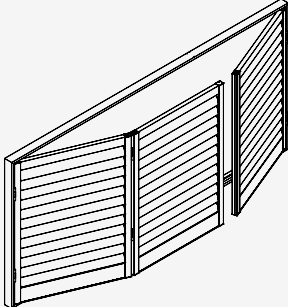
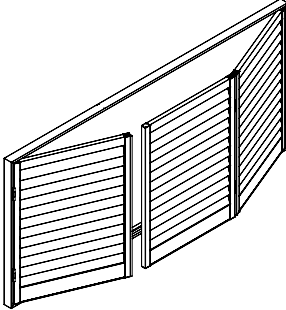
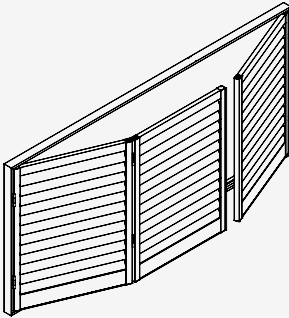
Drawing	Panel Configuration Code
	LD-R - 2
	LL-DR - 3
	LD-RR - 3
	LLD-R - 3

FRAME BUILDOUT FOR L FRAME ONLY, OUTSIDE MOUNT

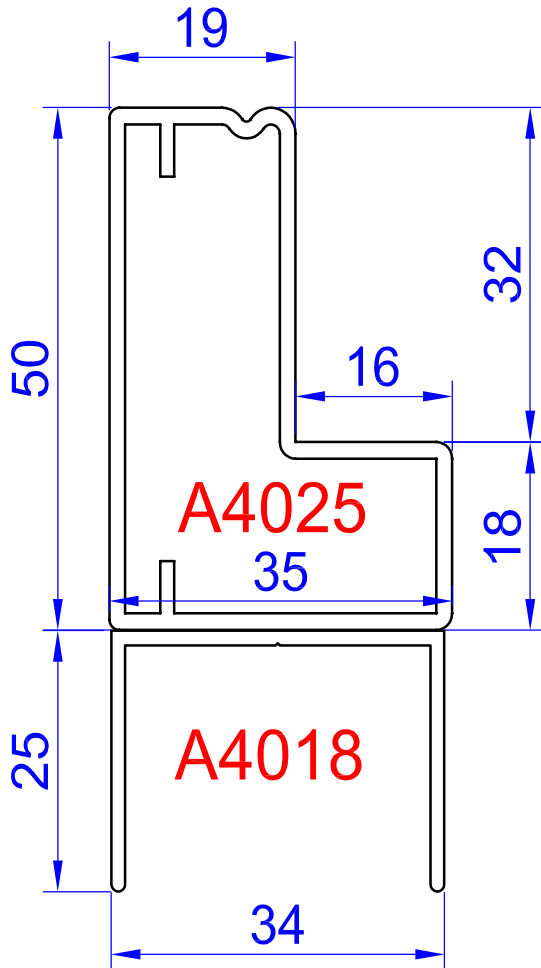

To allow for full rotation of blades on a outside mount L frame the following channel sizes can be added to the back of the frame.

89mm Blade = 25mm Channel
114mm Blade = 50mm Channel

Important Note:

Max Length is 6000mm. For lengths greater than 6000mm, buildout will be cut in half.

INSTALLATION METHOD: FIXED IN CHANNEL



BEFORE YOU ORDER:

WARRANTY LIMITS

Installation Method	Width			Height			Mid-Rail(s) Required	Panel Breaks		
	Min	Max	Max Non Warranty	Min	Max	Max Non Warranty		Approximate Split Rotation by Blade Size*		
								64	89	114
Fixed	200	1500	1600	400	3400	N/A	2000, 3000	1000/ 20 Blades	1200/ 13 Blades	1200/ 10 Blades

*** Important Note:**

The factory will automatically split the rotation if the size exceeds factory standards as noted above.

MINIMUM REVEAL DEPTH*

*Be sure to always measure from the most protruding object in the reveal.

Installation Method	Clearance 64mm Blade	Clearance 89mm Blade	Clearance 114mm Blade
Fixed	54	67	79

DEDUCTIONS

Fixed Panel and Reveal	Between Meeting Panels	Overall Panel Deduction
2.5	2.5	5

TOP CHANNEL

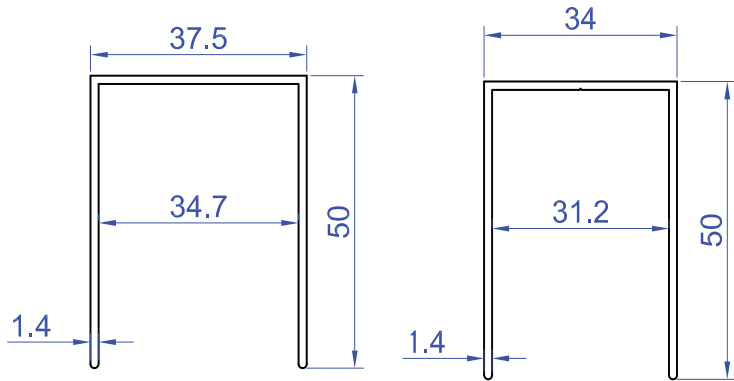

Used with H Section

A4015

Used with No H Section

A4017**Important Note:**

Max Length is 6000mm. For lengths greater than 6000mm, channels will be cut in half.

BOTTOM CHANNEL

Used with H Section

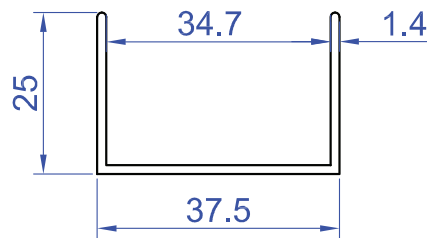
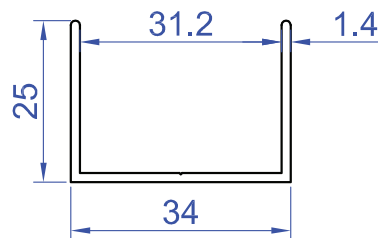
A4016Used with No
H Section
Also used as Side
Channel**A4018****Important Note:**

Max Length is 6000mm. For lengths greater than 6000mm, channels will be cut in half.

L ANGLE

25x25 angle is supplied when 'U Channel with Angle Front Only' is selected at ordering.

25x10 angle is supplied when 'U Channel with Angle Front & Back' is selected at ordering.

Installation Method*: Fixed

Installation Type*: - select here -
 U Channel All Sides
 U Channel Top & Bottom Only
 U Channel with Angle Front & Back
 U Channel with Front Angle Only

Mount*:
 Panel Configuration*: - select here -

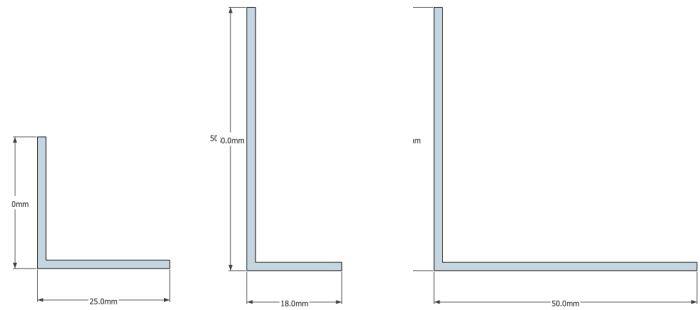

25mm x 25mm Angle

50mm x 18mm Angle

50mm x 50mm Angle

Important Note:

Max Length is 6000mm. For lengths greater than 6000mm, angles will be cut in half.

H SECTION & ANGLES

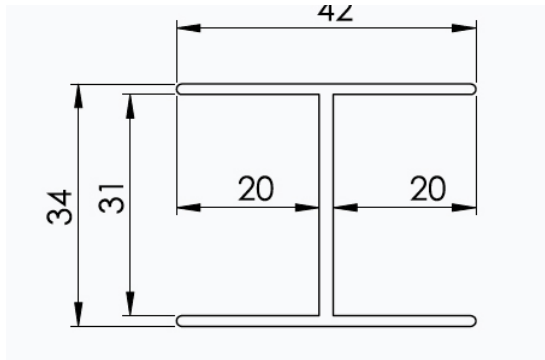

H Section

Important Note:

Max Length is 6000mm. For lengths greater than 6000mm, channels will be cut in half.

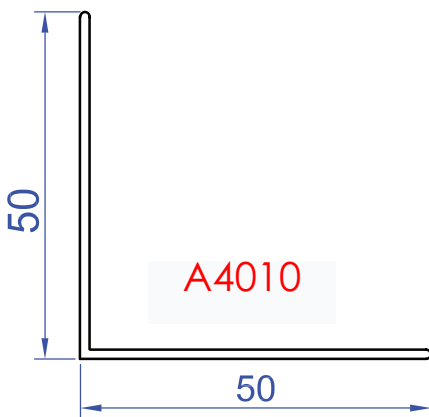

50mm x 50mm Angle

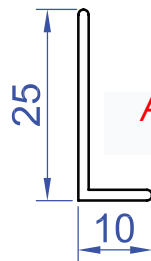

25mm x 10mm Angle

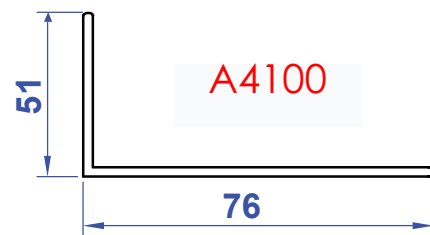

51mm x 76mm Angle

PANEL CONFIGURATIONS

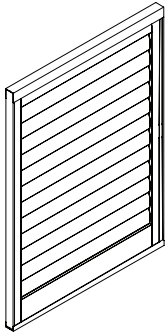
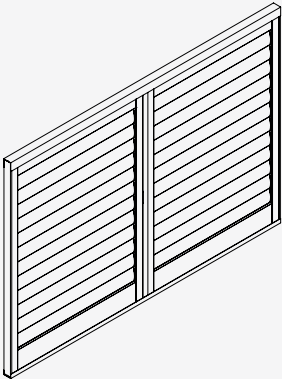
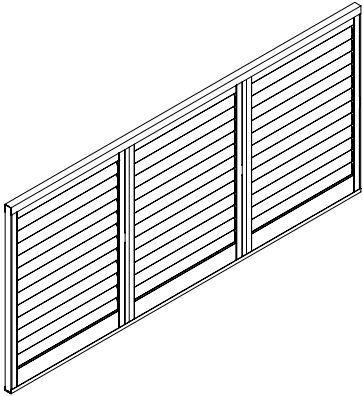
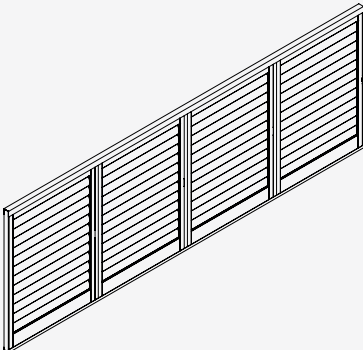
Drawing	Panel Configuration Code
	<p>F - 1</p>
	<p>FHF - 2</p>
	<p>FHFHF - 3</p>
	<p>FHFHFHF - 4</p>

Other Available Configurations:
 FHFHFHFHF - 5
 FHFHFHFHFHF - 6

Available Mounts - Reveal (In).

INSTALLATION METHOD: SLIDING



BEFORE YOU ORDER:

WARRANTY LIMITS

Installation Method	Width			Height			Mid-Rail(s) Required	Panel Breaks		
	Min	Max	Max Non Warranty	Min	Max	Max Non Warranty		Approximate Split Rotation by Blade Size*		
								64	89	114
Sliding	200	1500	1600	400	3400	N/A	2000, 3000	1000/ 20 Blades	1200/ 13 Blades	1200/ 10 Blades

*** Important Note:**

The factory will automatically split the rotation if the size exceeds factory standards as noted above.

MINIMUM REVEAL DEPTH*

*Be sure to always measure from the most protruding object in the reveal.

Installation Method	Clearance 64mm Blade	Clearance 89mm Blade	Clearance 114mm Blade
2 Tracks Sliding, Blades Closed	95	108	121
2 Tracks Sliding, Blades Open	131	170	209

DEDUCTIONS

Top Track	Surface Mount Track	Bottom Track Recessed
52	20	10

TOP TRACK

DOUBLE SIDED FASICA
INSTALLATION OPTION 1

Available Mounts - Reveal (In).

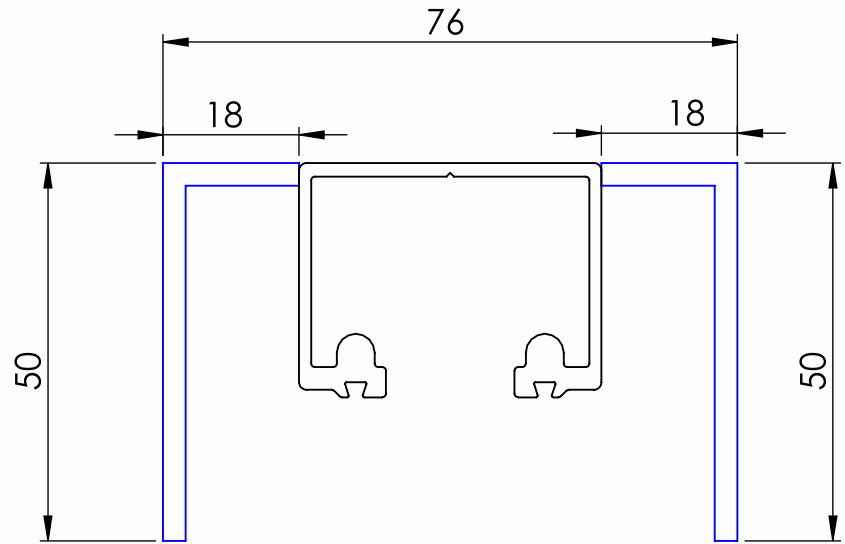
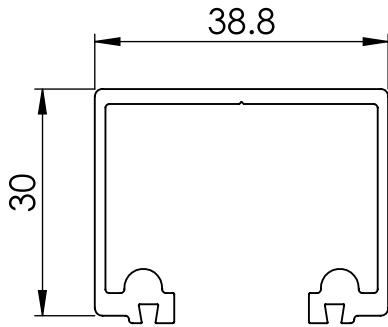

Important Note:

Max Length is 6000mm. For lengths greater than 6000mm, tracks will be cut in half.

BOTTOM TRACK

DOUBLE SIDED FASICA
INSTALLATION OPTION 2

Available Mounts - Reveal (In).

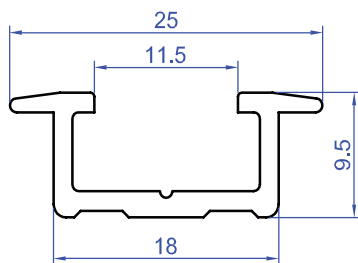
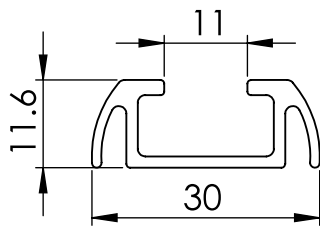

Recessed Bottom Track (7014)

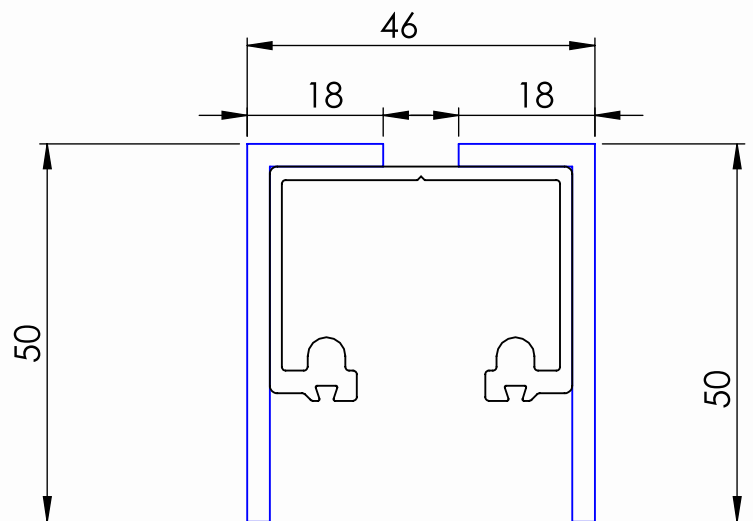

Important Note:

Max Length is 6000mm. For lengths greater than 6000mm, tracks will be cut in half.

PANEL CONFIGURATIONS

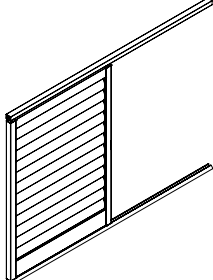
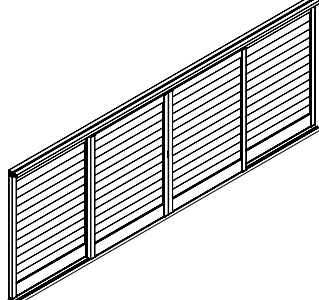
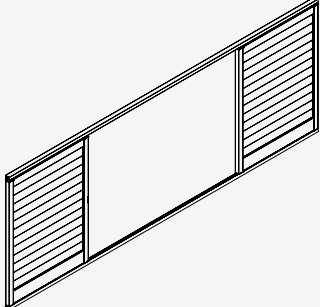
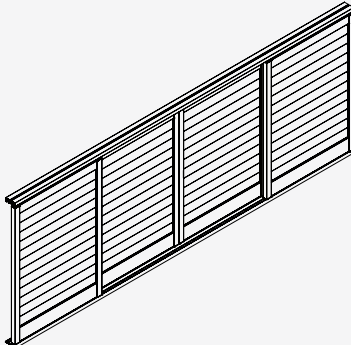
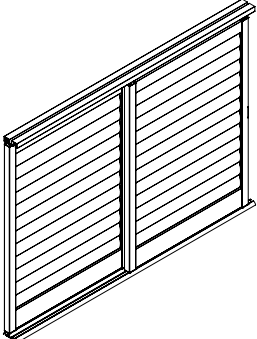
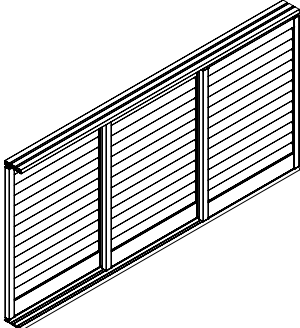
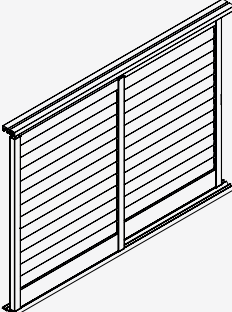
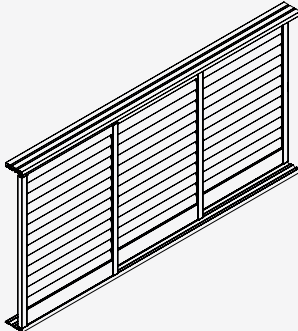
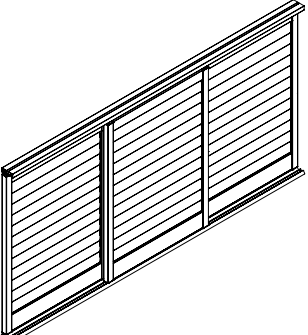
Drawing	Panel Configuration Code	Drawing	Panel Configuration Code
	1 Track S - 1		2 Tracks BFFB - 4
	1 Track SS - 2		2 Tracks FBBF - 4
	2 Tracks BF - 2		3 Tracks BMF - 3
	2 Tracks FB - 2		3 Tracks FMB - 3
	2 Tracks BFB - 3	<p>Other Available Configurations: BFBFBF - 6 (2 Tracks) BMFFMB - 6 (3 Tracks) FMBBMF - 6 (3 Tracks)</p>	

HEADBOARDS

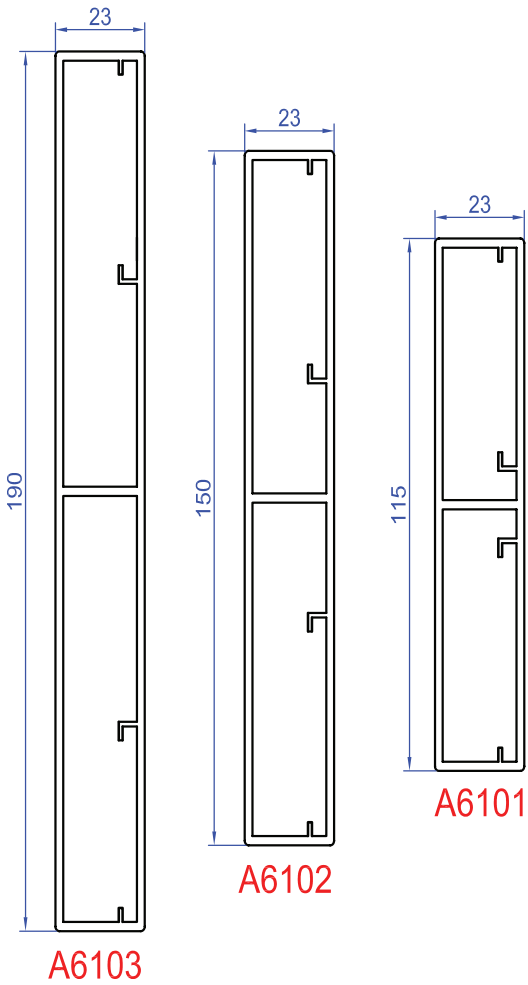
**Available Sizes:**

A6101 115mm x 23mm

A6102 150mm x 23mm

A6103 190mm x 23mm

Note:

A 40mm x 40mm aluminum angle will be provided for an outside mount.

It is recommended that headboard brackets are also ordered for additional mounting support. These can be ordered in Extras.

As standard, all headboard orders will be supplied with a double sided fascia. Sideboards and returns are available as needed (linear meter charges apply).

INSTALLATION METHOD: MULTI-FOLD



BEFORE YOU ORDER:

WARRANTY LIMITS

Installation Method	Width			Height			Panel Breaks			
	Min	Max	Max Non Warranty	Min	Max	Max Non Warranty	Mid-Rail(s) Required	Approximate Split Rotation by Blade Size*		
								64	89	114
Multi-Fold	200	700	750	400	3400	N/A	2000, 3000	1000/ 20 Blades	1200/ 13 Blades	1200/ 10 Blades

*** Important Note:**

The factory will automatically split the rotation if the size exceeds factory standards as noted above.

MINIMUM REVEAL DEPTH*

*Be sure to always measure from the most protruding object in the reveal.

Installation Method	Clearance 64mm Blade	Clearance 89mm Blade	Clearance 114mm Blade
Multi-Fold	54	67	79

DEDUCTIONS

Top Track	Bottom Track	Bottom Track Recessed	Bottom Multi-Fold Pivot Height	Bottom Multi-Fold Pivot Width
52	20	28	20	5

TOP TRACK

DOUBLE SIDED FASICA
INSTALLATION OPTION 1

Available Mounts - Reveal (In).

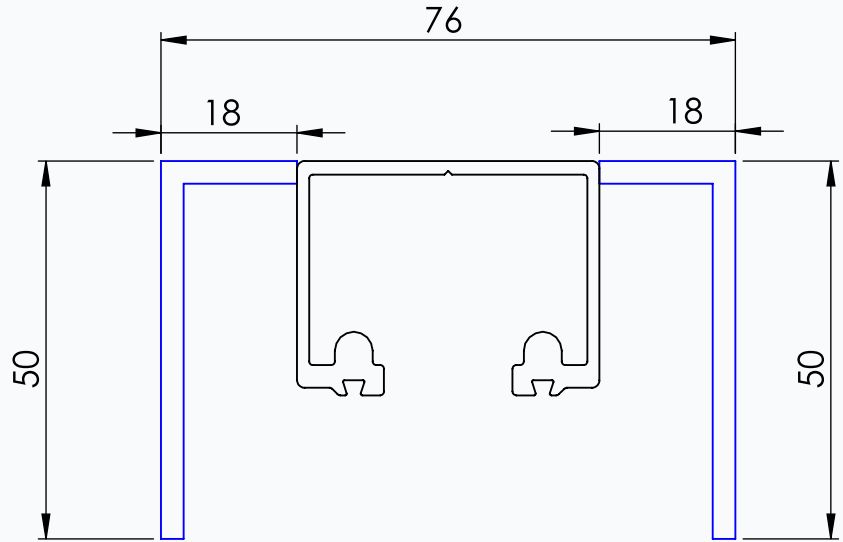
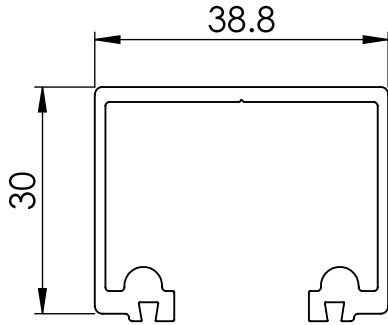

Important Note:

Max Length is 6000mm. For lengths greater than 6000mm, tracks will be cut in half.

BOTTOM TRACK

DOUBLE SIDED FASICA
INSTALLATION OPTION 2

Available Mounts - Reveal (In).

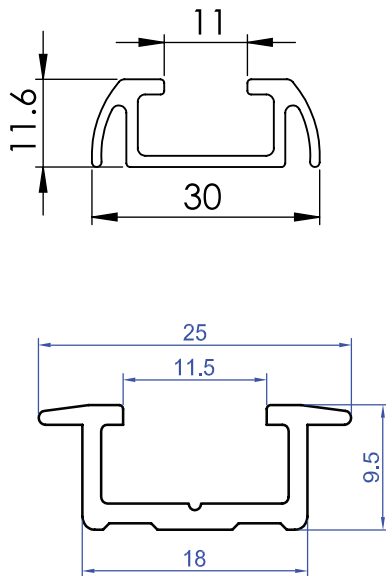

Recessed Bottom Track (7014)

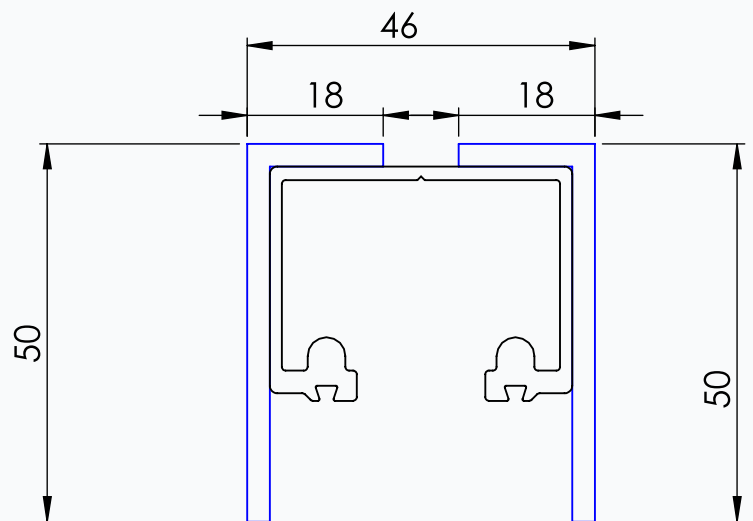

Important Note:

Max Length is 6000mm. For lengths greater than 6000mm, tracks will be cut in half.

PANEL CONFIGURATIONS – STANDARD FOLD

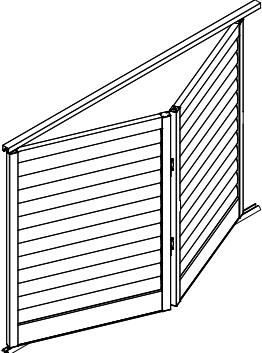
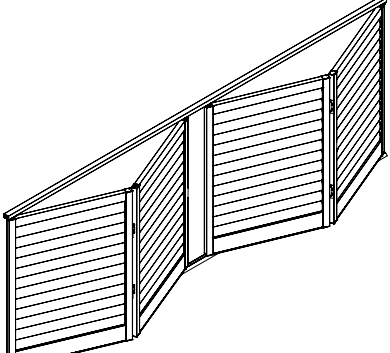
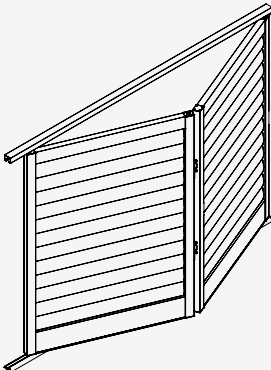
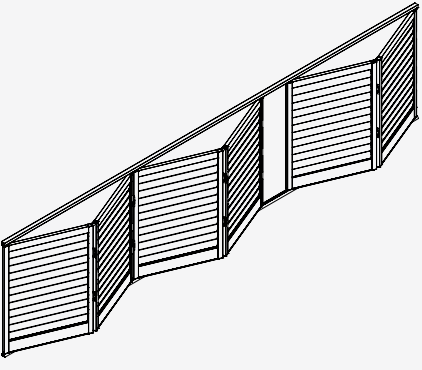
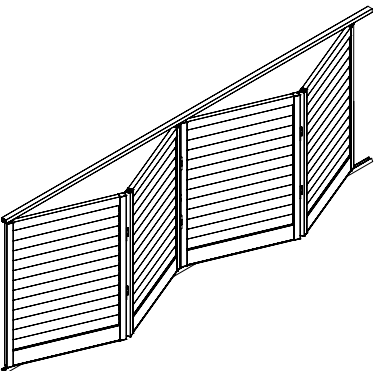
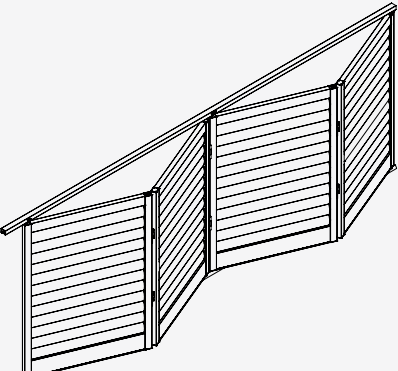
Drawing	Panel Configuration Code	Drawing	Panel Configuration Code
	LL - 2		LLRR - 4
	RR- 2		LLLLRR - 6
	LLLL - 4	<p>Important Note: The maximum number of panels folding in one direction is eight. Panel configurations are to be an even number and move in pairs. This ensures that each panel is able to be secured in the opening. Flush bolts are mandatory for all multi-folds and will be on the on the below panel numbers (NB: panels are from left hand side) LLLLLLLL - Panels 2, 4, 6 & 8 RRRRRRRR - Panels 1, 3, 5, & 7.</p>	
	RRRR - 4		

PANEL CONFIGURATIONS – REVERSE FOLD

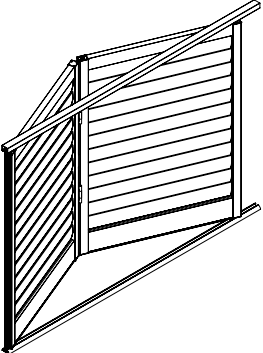
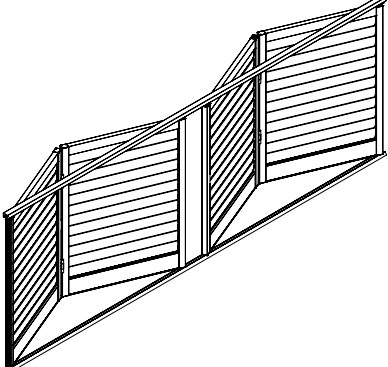
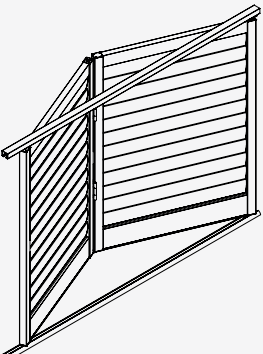
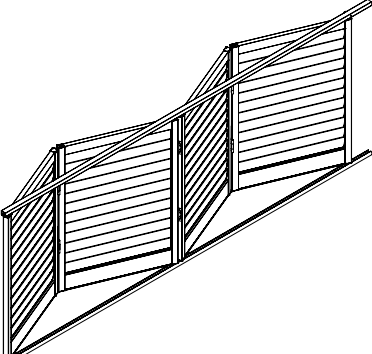
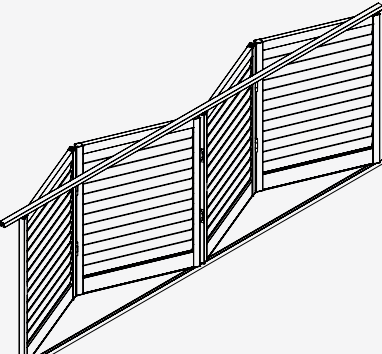
Drawing	Panel Configuration Code	Drawing	Panel Configuration Code
	LL - 2		LLRR - 4
	RR - 2	<p>Important Note: The maximum number of panels folding in one direction is four. Panel configurations are to be an even numbers and move in pairs. This ensures that each panel is able to be secured in the opening.</p>	
	LLLL - 4		
	RRRR - 4		

Other Available Configurations:
 LLLLRR - 6
 LLRRRR - 6

PRE-DRILLING OF FRAMES

If requested in Special Instructions, the factory will pre-drill countersunk holes as per the following guideline:

- A) On the left and right frame 250mm from the corner a hole will be drilled.
- B) If the left and right frame length is greater than 2500mm, an additional hole will be drilled at the mid point on each side.
- C) If the top and bottom frame length is greater than 1000mm a hole will be drilled at the mid point also.

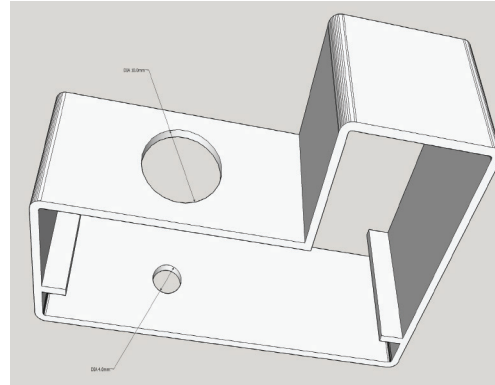
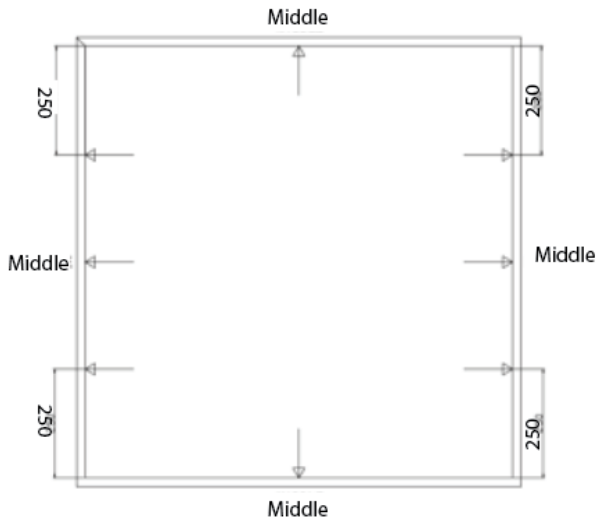

Note: The first drill hole will be 10mm in diameter and a cap will be supplied to hide the screw. The second hole will be 4mm in diameter for the screw fixing.

HEADBOARDS

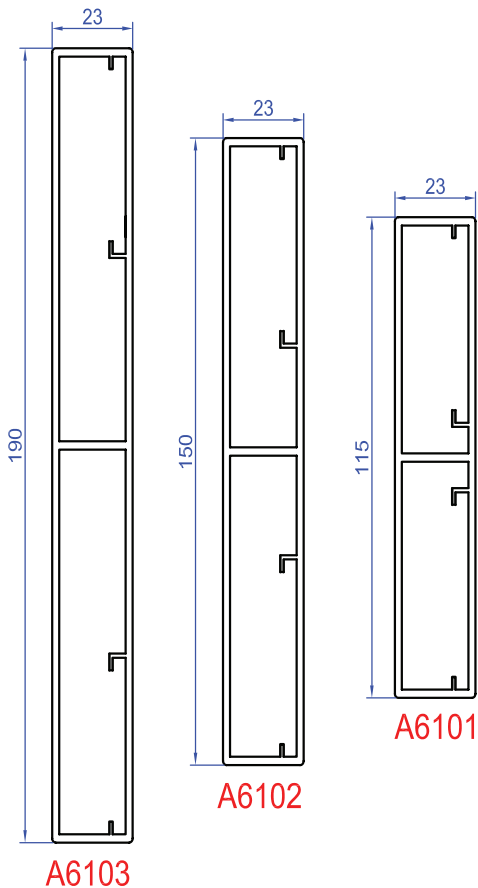

Available Sizes:

A6101 115mm x 23mm

A6102 150mm x 23mm

A6103 190mm x 23mm

Note:

A 40mm x 40mm aluminum angle will be provided for an outside mount.

It is recommended that hardboard brackets are also ordered for additional mounting support. These can be ordered in Extras.

As standard, all headboard orders will be supplied with a double sided fascia. Sideboards and returns are available as needed (linear meter charges apply).

SHAPED SHUTTERS

SLOPES LEFT & RIGHT

Available Installation Methods:

- Fixed
- Hinged in Frame

Important Note:

Blade(s) in the sloped section will be fixed, all other blades will be operable.

Please allow additional lead time for sloped shutter orders. If you are unsure if the shape is available for this product range, please contact your sales representative.

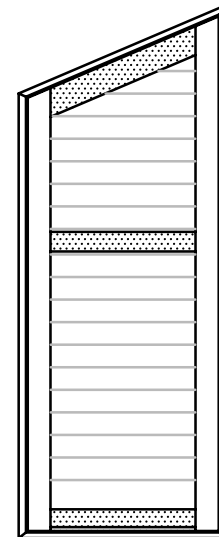

Slope Left

How To Order:

1. Click on the pencil for Shaped Shutter

Color*: Black. Split Rotation Height

Blade*: 114mm

Tilt Rod*: Dual Clearview Bac

Stiles*: 60mm Beaded

Installation Method*: Fixed

Installation Type*: U Channel All Sides

Mount*: Reveal (In)

Panel Configuration*: FHF - 2

Shaped Shutter

2. Select Shape Type - Slope Left or Slope Right

Shaped Shutter

Shape Type: - select here -

- Slope Left
- Slope Right

Height 2:

3. Enter Height 2 measurement

Shaped Shutter

Shape Type: Slope Left

Height 2:

EXTRAS

FLUSH BOLTS

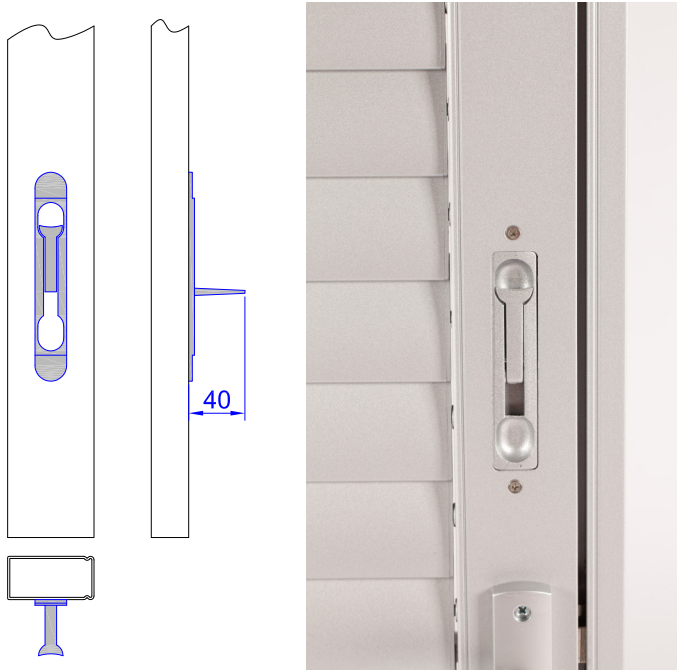

Available Installation Methods:

- Hinged in Frame
- Hinged No Frame
- Multi-Fold (bottom only)

Avialbe Colours:

- White A9400
- Silver A9401
- Black A9402

Important Note:

Flush bolts can not be fitted to the section of the panels where the hardware is attached to the tracking system.

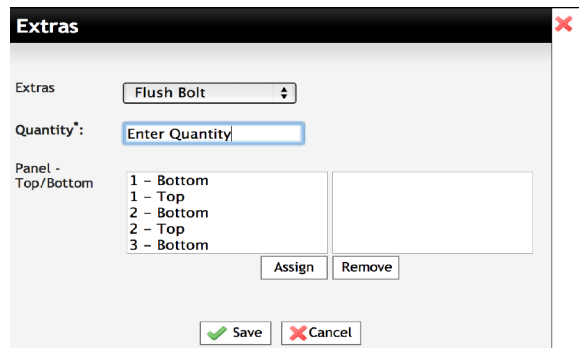

SECURITY BOLT



Available Installation Methods:

- Hinged in Frame
- Hinged No Frame

Important Note:

The security bolt is stainless steel and is placed at the top or bottom of the selected panel(s) stile on the opposite side of the hinges.

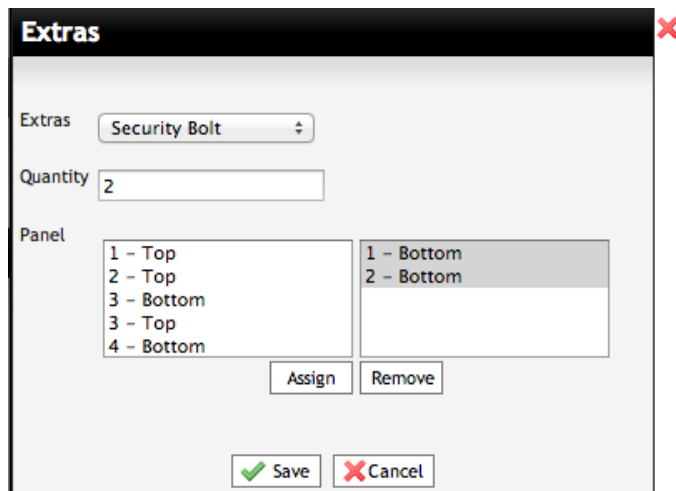

EXTRAS

LOCKABLE HANDLE



Black internal plate

Available Colours:

Black - A9202
White - A9201

Important Note:

This handle can be dead locked.
Black and white handles will come standard with a black internal plate.

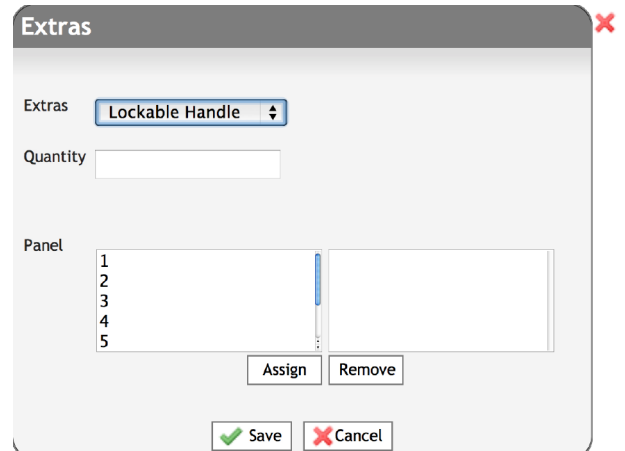

FLY SCREEN UNIT – FIBERGLASS

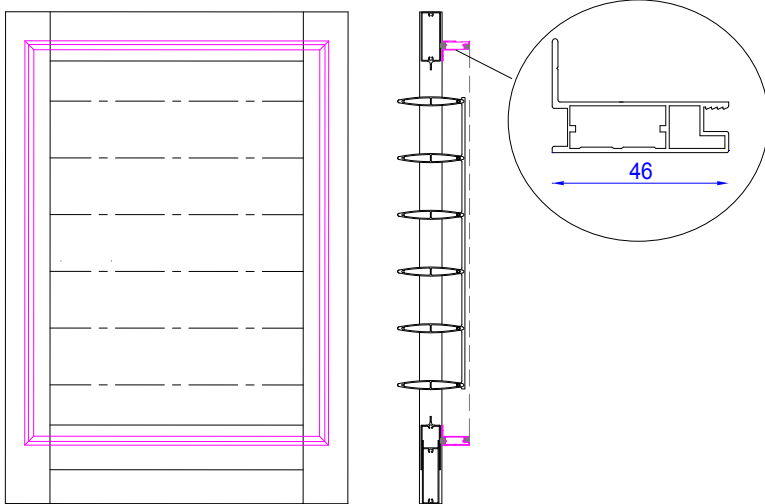

Available Installation Methods:

Hinged in Frame, Fixed.

Available Colours:

Black

Important Note:

If a flyscreen unit is ordered in addition to a handle, the blades above and below the mid-rail will be fixed in position to allow for operation of handle

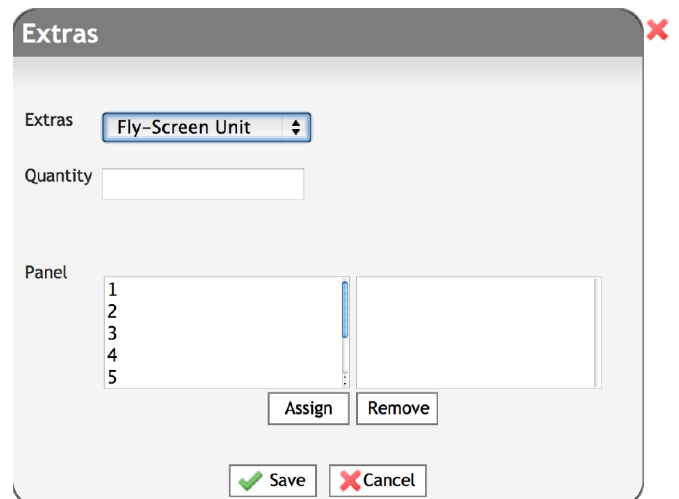

EXTRAS

FLY SCREEN UNIT – ALUMINUM MESH (A9003)

Available Colours:

Black

Installation Type:

Currently only available for a Fixed in Top and Bottom U Channel installation type.

Important Note:

Maximum size is 1000mm x 2500mm.

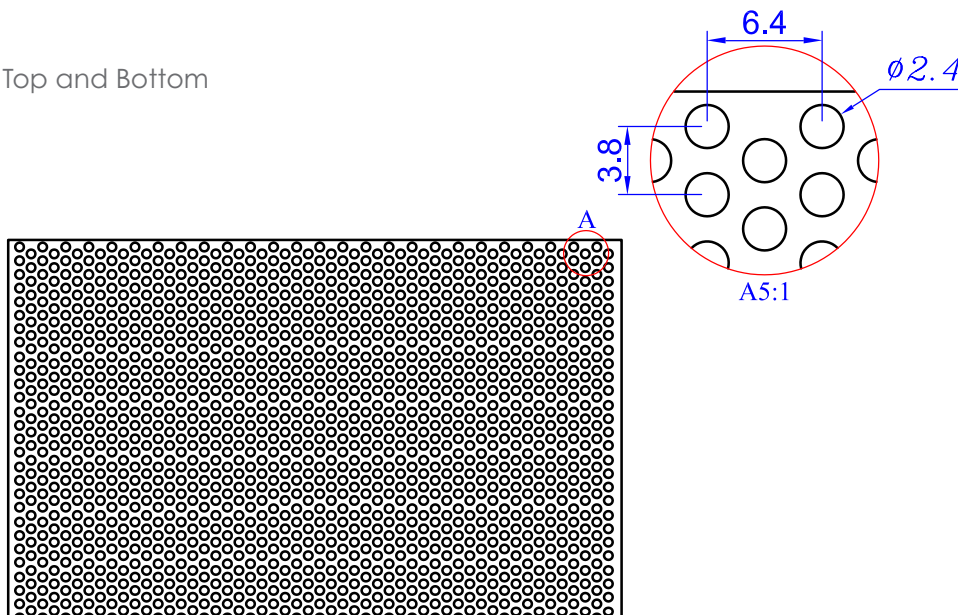

BLADE STAY (A9000)

**Available Colours:**

Black

White

Important Note:

A blade lock is required every 1300mm or where a split rotation is required. Max panel height is 1800mm and will require 2x blade locks. If a panel has a mid-rail, a Blade Lock will be required both above and below the mid-rail to operate each section independently.

Positioning: If uneven number of blades, it will default to one blade below centre of section of blades.

Extras

Extras

Quantity:

EXTRAS

DOUBLE SHOOT BOLT (A9300)



Available Installation Methods:

Hinged in Frame

Important Note:

Available with a key lock only. Note: All openings will be keyed alike as standard for each order.

Double Shoot Bolt default position is centre unless specified in notes.

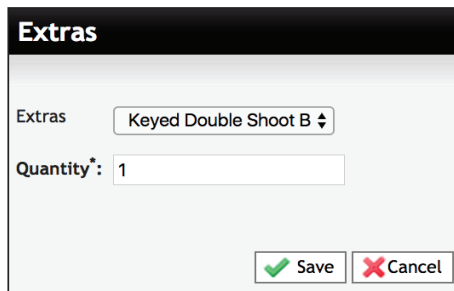

STAND OUT BRACKET



Available Colours:

Powdercoated to match.

Installation Type:

Currently only available for a Fixed in Top and Bottom U Channel installation type. Can be applied to other applications on request - please check with Head Office first.

Minimum width of Stand Out Bracket is 100mm. Max width is 600mm.

Ordering Note:

As standard these will come at the width ordered top and bottom, however please advise the projection from the wall in the notes when ordering.

Choose for either the standard foot (A4048) or concealed foot (A4048S)

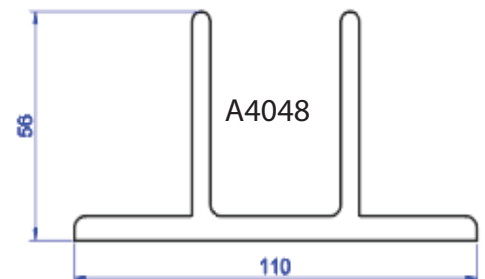
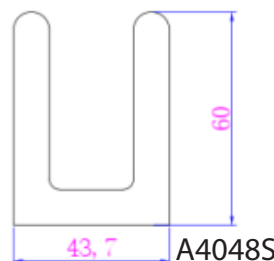
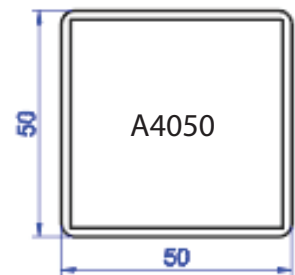
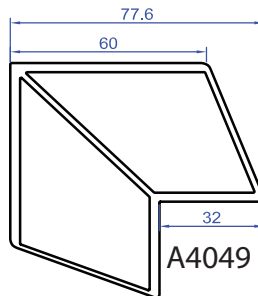

EXTRAS

ANGLES

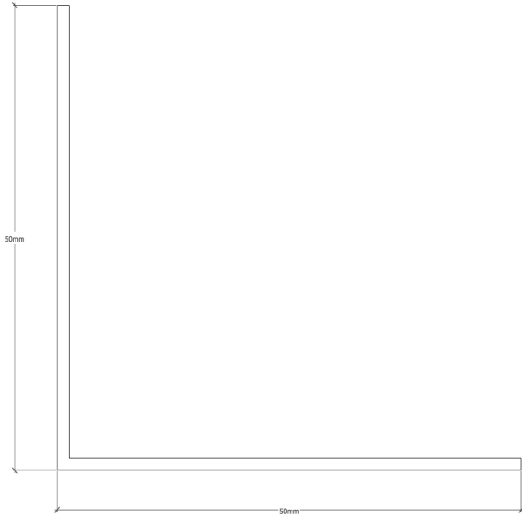

50 x 50 Angle
A4010

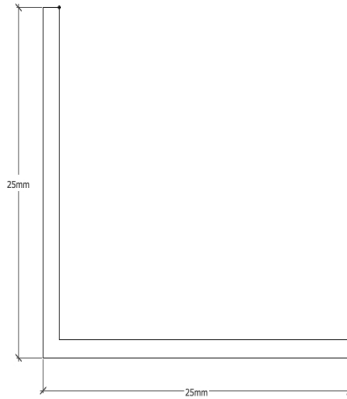

25 x 25 Angle
A4007

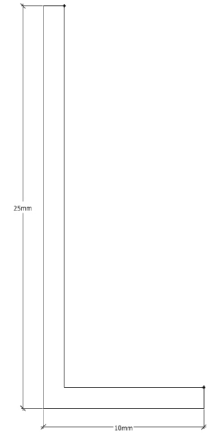

25 x 10 Angle
A4014



51 x 76 Angle
A4100



50 x 3 Flat Bar
A4002

Available Colours:
Powdercoated to match.

Important Note:
Max Length is 6000mm. For lengths greater than 6000mm, angles will be cut in half.

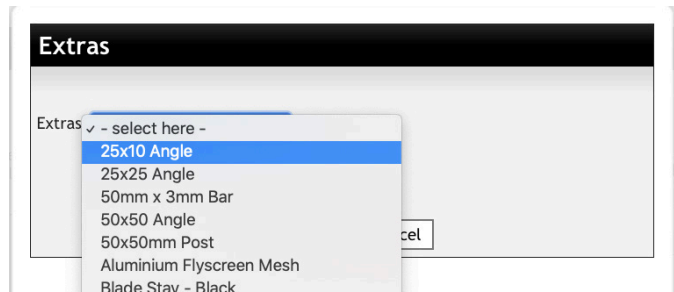

EXTRAS

HEADBOARD BRACKETS

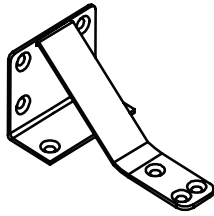
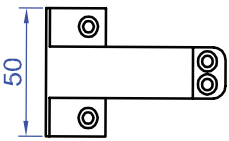
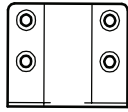
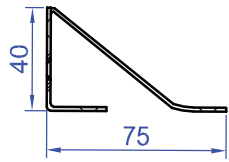

75mm

Available Colours:

White

Available Sizes

75mm

100mm

135mm

180mm

Designed to assist in supporting the headboard.

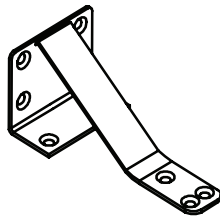
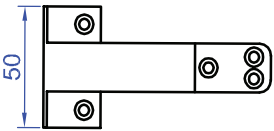
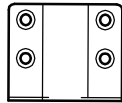
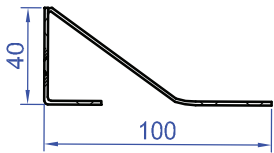

100mm

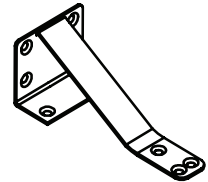
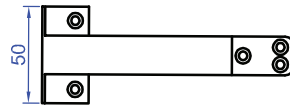
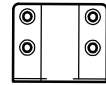
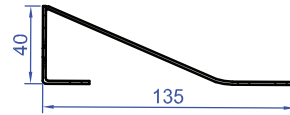

135mm

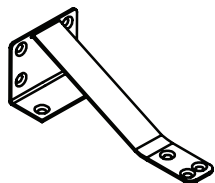
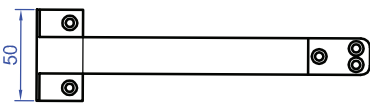
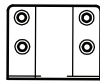
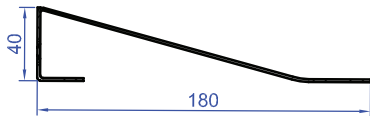

180mm

EXTRAS

DUAL CONTROL TILT ROD

**Available Installation Methods:**

All

Important Note:

Available for all blades sizes. Surcharge item for 64mm and 89mm blade.

UNIVERSAL PULL STICK

Open shutter blades with ease in out of reach installations for light adjustment.

Available in White.

HOW TO ORDER:

Select from the *Extras* drop-down menu.



EXTRAS

CUPBOARD CATCH

Designed to hold firmly and prevent doors swinging open during windy conditions. The catch is made from plastic and installed with a stainless steel screw (rust proof). No surcharge applicable.

HOW TO ORDER:

When placing your order, please select *Cupboard Catch* from the *Extras* drop-down.



SPECIAL INSTRUCTIONS

10mm Door Clearance - The factory will take an additional 10mm deduction off the height of the opening to allow for clearance in doors.

B-Folding Panels - Multiple panels are hinged together off the one side of the opening with no top or bottom track. For hinged in Frame and Hinged No Frame installation methods only.

Critical Mid-Rail - Height of mid-rail specified in column 1 of the order form is to be at that exact height. Please note this may result in large/small top and/or bottom rails.

Hinges Loose - Hinges for the line item will be supplied loose in the components box and not attached to the panels.

Internal Installation Required - Shutters will be installed inside a home or commercial building, not in an external application.

Magnets Loose - Magnets will be supplied loose in the components box and not attached to the panels.

Tier on Tier - Shutters in a Hinged in Frame installation method will be installed as two stacks, one on top of the other. Shutters in each section are able to operate independently of each other. A horizontal t-post may be required for openings over a specific, please confirm with the factory.

Pre-Drill Frames - Upon request factory will countersink holes in the frame. The first drill hole will be 10mm in diameter and a cap will be supplied to hide the screws. The second hole will be 4mm in diameter for the screw fixing.

PRODUCT MAINTENANCE

A COMMON MISCONCEPTION IS THAT STAINLESS STEEL IS NOT EFFECTED BY CORROSION OR RUST.

Corrosion Potential	Distance to Saltwater Area	Cleaning Schedule
Low (LCP)	20 km radius	Every 6 months
Moderate (MCP)	10 km radius	Every 3 months
High (HCP)	1 km radius	Every 3 weeks
Extreme (ECP)	500 meter radius	Every week

Stainless steel hardware and fittings are used to resist rust and corrosion in coastal, saltwater atmospheres. In these environments, where two dissimilar materials such as stainless steel and aluminum are combined, a corrosive reaction will occur if not properly maintained.

Proximity to fresh water is not commonly considered a risk but we also recommend the implementation of our maintenance procedure in these areas as well.

By following the guidelines listed in this document, corrosion of essential components can be avoided. This information is only a guide and not a guarantee against set corrosion.



MAINTENANCE PROCEDURE

- Step 1** Clean the shutters using a nonabrasive cloth or sponge with warm soapy water. A garden hose may also be used. Concentrate on the areas where the stainless steel hardware is attached to the shutter.
- Step 2** Make sure to remove any salt residue, tannin stains caused by trees and any other marks created by local industry / automotive exhaust residue, as these chemicals also have corrosive properties.
- Step 3** On completion of the cleaning process, spray a light film of silicone lubricant to any operational hardware such as the tracking system. Please ensure these areas are fully dry prior to this application.